

## Thermostat with keypad

Instruction-Ver1.0

Item No.: LC-PBST04



## Content

<b>1. Summary</b> .....	<b>3</b>
<b>2. Function features</b> .....	<b>3</b>
2.1 Product description .....	3
2.2 Functional Overview .....	4
<b>3. Specification</b> .....	<b>6</b>
<b>4. Dimensional drawings and wiring diagrams</b> .....	<b>6</b>
<b>5. Product operation and installation instructions</b> .....	<b>7</b>
5.1 Product operation .....	7
5.2 Product Installation Instructions .....	8
<b>6. Parameter Setting Instructions</b> .....	<b>9</b>
6.1 Parameter setting interface.....	10
6.1.1 Button interface .....	10
6.1.2 Switching .....	12
6.1.3 Blind .....	15
6.1.4 Dimming .....	17
6.1.5 Scene .....	20
6.1.6 Value send.....	21
6.1.7 Multiple operation .....	25
6.1.8 Shift function.....	27
6.1.9 RGB dimming .....	29
6.1.10 Delay mode .....	31
6.1.11 Operation for local thermostat .....	32
6.1.12 Operation for local actuator——Not available .....	34
6.1.13 Status LED .....	34
6.1.13 LED settings .....	36
6.2 Parameter setting interface-Mixed Thermostat.....	40
<b>6.2.1 Air conditioning</b> .....	43
6.2.2 HVAC.....	45
6.2.3 Floor heating .....	59
<b>6.2.4 Ventilation system</b> .....	60
6.2.5 Thermostat backlight .....	63
6.3 Parameter setting interface Mixed Actuator —— Not available .....	67
6.4 Parameter setting interface Scene Module.....	67
6.5 Parameter setting interface Logic Function .....	70
6.5.1 OR, AND, XOR, NOR, NAND, XNOR function parameters .....	70
6.5.2 Threshold comparator function parameters .....	72
6.5.3 Data converters function parameters.....	73
6.6 Device status .....	75
6.7 Buzzer status .....	75
6.8 Setting for reading object —— Not available.....	76
<b>7. Communication object description</b> .....	<b>76</b>
7.1 Communication object of "Button interface" .....	76
7.1.1 Communication object of "Switching" .....	76

7.1.2 Communication object of "Blind" .....	78
7.1.3 Communication object of "Dimming" .....	80
7.1.4 "Scene" Communication Object .....	81
<b>7.1.5 Communication object of "Value send" .....</b>	<b>82</b>
7.1.6 Communication objects of "Multiple operation" .....	84
7.1.7 Communication object of "Shift function" .....	85
7.1.8 Communication object of "RGB dimming" .....	86
7.1.9 Communication object of "Delay mode" .....	87
7.1.10 Communication objects for "Operation for local thermostat" .....	88
7.1.11 Communication object of "Operation for local actuator" .....	89
7.1.12 Communication object of "Status LED" .....	89
7.1.13 Communication partner of "LED settings" .....	90
<b>7.2 Communication object of "Mixed Thermostat" .....</b>	<b>93</b>
7.2.1 "Air conditioning" Mode .....	93
7.2.2 "HVAC" Mode .....	95
7.2.3 "Floor heating" Mode .....	99
7.2.4 "Ventilation system" Mode .....	100
7.2.5 "Actual temperature" function .....	102
7.2.6 "Actual humidity" function .....	102
7.2.7 "Air quality" function .....	103
7.2.8 "Thermostat backlight" mode .....	104
7.3 Communication object of "Mixed Actuator" — Not available .....	108
7.4 Communication object of "Scene Module" .....	108
7.5 Communication object of "Logic Function" .....	110
7.5.1 "OR, AND, XOR, NOR, NAND, XNOR" mode .....	110
7.5.2 "Threshold comparator" mode .....	112
7.5.3 "Data converters" mode .....	114
7.6 Communication object "Device status" .....	124
<b>8. Safe use and maintenance .....</b>	<b>124</b>
<b>9. Contact .....</b>	<b>125</b>

## 1. Summary

This manual provides you with detailed technical information on controlling the multifunctional temperature control panel, including installation and programming details, and explains how to use the device based on practical examples. The multifunctional temperature control panel is installed in a standard 80/86 base box, which is easy to install and disassemble;

The multifunctional temperature control panel is mainly used for FCU control or air conditioning control, floor heating control, fresh air control, lighting control, scene control, etc. It has both thermostats function and switch panel function. Users can adjust the function configuration according to their needs. The screen only displays the current control status of the thermostat.

It is installed together with other devices through the EIB/KNX bus to form a system.

Use the engineering design tool software ETS to set up and operate the entire system.

## 2. Function features

### 2.1 Product description

The multifunctional temperature control panel is mainly used in intelligent control systems. It can be combined with other devices on the bus, connected to the bus through KNX terminals, and installed together to form a system. The function is simple and intuitive. Users can plan according to their needs and execute these functions systematically.

The multifunctional temperature control panel can control air conditioning, fresh air and floor heating equipment through the screen. At the same time, the mechanical buttons also have functions such as control switches, curtains, dimming, scenes, value sending, multiple operations, shift registers, RGB/RGBW dimming, delay mode, scene module conversion, logic output, etc., and built-in temperature sensors can detect local ambient temperature; each channel on the panel includes a button and an LED indicator, and each channel can use the various functions described above, and they are independent of each other; in addition, the mechanical buttons can also be mapped to the function buttons of the temperature control screen, which can be used to control switches, mode switching, wind speed adjustment, etc.

The multifunctional temperature control panel adopts the standard 80/86 box wall-mounted installation method, is powered

by the KNX bus, is connected to the EIB/KNX system through the EIB bus, and uses the engineering design tool ETS software (version ETS4 or above) to allocate physical addresses and group addresses and set parameters;

## 2.2 Functional Overview

Output	Function description
<p style="text-align: center;">Thermostat screen  function</p>	<p>( 1 ) AC control function output;</p> <p>( 2 ) Fresh air control function output;</p> <p>( 3 ) Floor heating control function output;</p> <p>( 4 ) Display feedback function of AC, fresh air, floor heating and switch;</p> <p>( 5 ) Display feedback function of the temperature setting of AC and floor heating;</p> <p>( 6 ) Display feedback function of the fan speed setting of AC and fresh air, support low, medium and high speed;</p> <p>( 7 ) Air conditioning mode setting and feedback display, including cooling, heating, air supply, dehumidification and other modes ;</p> <p>( 8 ) It has dedicated display pages for air conditioning, floor heating, fresh air, humidity, etc.;</p> <p>( 9 ) Built-in infrared sensor, easily turn on the screen when someone comes and turn off when someone leaves;</p> <p>( 10 ) Built-in temperature sensor, supports Celsius and Fahrenheit temperature display;</p> <p>( 11 ) Supports fresh air system, air conditioning system, floor heating system, and fan coil control.</p>
<p style="text-align: center;">Switch function</p>	<p>( 1 ) Switch function, can be used to turn on and off lighting, with long press, short press and reverse functions;</p> <p>( 2 ) Dimming function, to control the dimming equipment, with relative dimming and absolute dimming function output;</p>

- ( 3 ) Curtain control function, which can control the opening and closing of curtains, the raising and lowering of projection screens, etc.
- ( 4 ) Value sending, can send 1bit/1byte value;
- ( 5 ) The scene control function can perform 8-bit scene control and call the set scene number;
- ( 6 ) Shift register, sending values in the form of shift register;
- ( 7 ) RGB and RGBW control, which can be controlled by long press or short press;
- ( 8 ) Multiple operation functions: one operation can send different values and call different types of functions at the same time;
- ( 9 ) Delayed sending of values: a value is sent or not sent during the operation, and another value is sent after a delay;
- ( 10 ) Logic output function, supporting OR, AND, XOR, NOR and NAND logic outputs;
- ( 11 ) Scene module conversion function, supporting scene group forwarding of up to 8 channels, and each group supports up to 8 configurable outputs;
- ( 12 ) LED indication function, you can choose a variety of display states, such as: Normally open, normally closed, flashing...
- ( 13 ) It has the master-slave function of the device lighting, and can be used as a host device or a slave device according to the needs;
- ( 14 ) The status and backlight LEDs have the functions of brightness wake-up and delayed extinguishing. The wake-up conditions include button pressing, object triggering, etc.

## 3. Specification

Bus Voltage	21-30 VDC , KNX bus
Bus Current	≤ 12mA
Bus power	≤ 360mW
Auxiliary voltage	24 VDC
Auxiliary current	< 30mA
Auxiliary power	< 1W
Temperature detection accuracy	±0.5°C
Working temp	-5°C...+45°C
Storage temp	-25°C...+55°C
Deliver temp	-25°C...+70°C
Relative humidity	max 90%
Material	Metal +PC
Size(H x W x D)	86X86X34 mm
Weight(approx.)	about 0.2kg
Installation	Standard 80/86 box

## 4. Dimensional drawings and wiring diagrams

Size

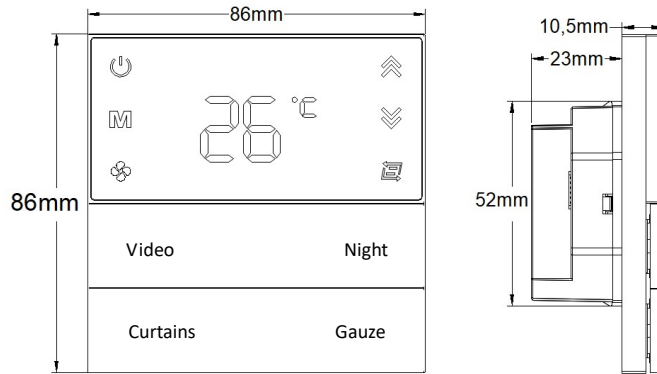

Diagram

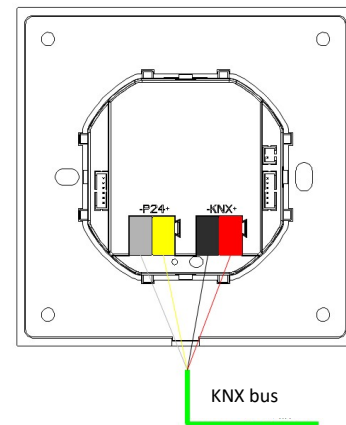

## 5. Product operation and installation instructions

### 5.1 Product operation

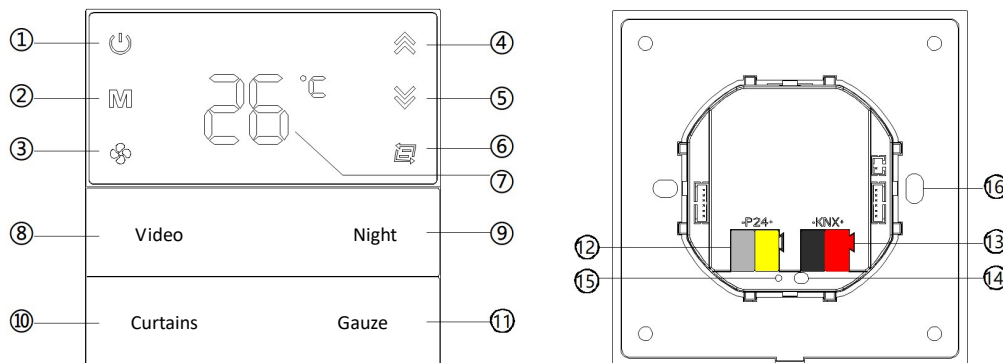

- ① Description: On/off button;
- ② Description: mode switch button, including heating mode, Air supply mode, dehumidification mode and cooling mode ;
- ③ Description: Fan speed adjustment button, used for the low speed, medium and high speed;
- ④ Description: temperature adjustment button, temperature “+” ;
- ⑤ Description: temperature adjustment button, temperature “-” ;
- ⑥ Description: Function switch button, air conditioning function interface → floor heating function interface → fresh air

function interface → air quality display interface;

- ⑦ Description: Display interface, switch status, temperature, wind speed and other display interfaces;
- ⑧ Description: Channel A, can be configured with mechanical key functions or functions in temperature screen ①~⑥;
- ⑨ Description: Channel B, can be configured with mechanical key functions or functions in temperature screen ①~⑥;
- ⑩ Description: Channel C, can be configured with mechanical key functions or functions in temperature screen ①~⑥;
- ⑪ Description: Channel D, can be configured with mechanical key functions or functions in temperature screen ①~⑥;

Each button has a feedback LED light, and each button needs to be engraved to be light-transmissive;

- ⑫ Description: Auxiliary power input;
- ⑬ Description : KNX power input;
- ⑭ Description: Programming button, Clicking the button for the first time enters programming mode, and clicking the button again cancels programming mode;
- ⑮ Description: Programming indicator light. When it lights up, the program state is entered. When it is in the programming state or the programming is completed, the indicator light will automatically go out.
- ⑯ Description: Fixed bracket, suitable for standard 86 bottom box installation;

## 5.2 Product Installation Instructions



1. The device is installed in a standard 86 bottom box;
2. First, use a screwdriver to install the KNX rear cover with the fixing bracket in the 86 bottom box;
3. Fit the button front cover and the KNX rear cover installed in the 86 bottom box together, pay attention to the hole position when fitting, and then gently press the panel to fix it;
4. When you need to remove the panel from the bottom box, use a flat-blade screwdriver to gently pry the fixing bracket at the groove at the bottom of the panel, and then pick up the loose button front cover by hand.

## 6. Parameter Setting Instructions

Let's take ETS5 as an example to set parameters in ETS5.

Open the parameter setting interface of the multi-function temperature control panel in ETS5. The "Panel functions" parameter setting interface is used to set the multi-function temperature control panel functions. The options are: Disabled (disabled) and Enabled (enabled), as shown in Figure 6.1.0.

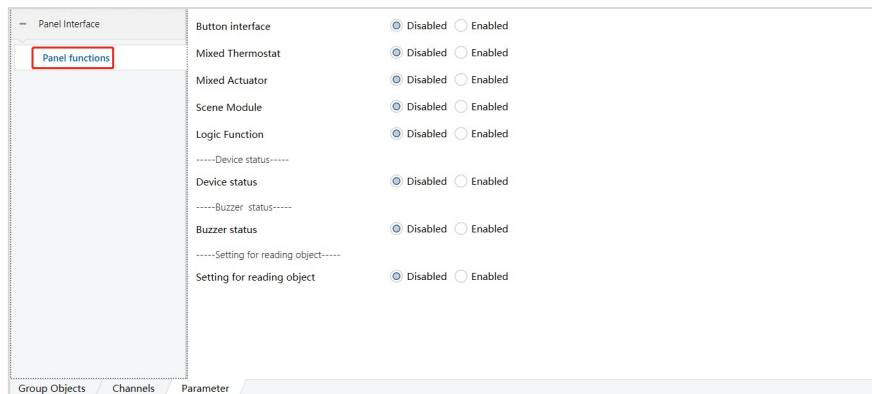

Figure 6.1.0

- 1 ) Button interface, button function setting ;
- 2 ) Mixed Thermostat , temperature function setting ;
- 3 ) Mixed Actuator , actuator function setting;—— Not available yet
- 4 ) Scene Module , switch scene module function setting ;
- 5 ) Logic Function , logic function setting ;

6 ) Device status , used for device status feedback ;

7 ) Buzzer status , buzzer function setting ;

8 ) Setting for reading object , set the time required to read the object ; — Not available yet

(Note: Different devices have different parameter settings. If the parameter setting of this device is marked as "not available", it means that it will not have the function of this parameter)

## 6.1 Parameter setting interface

### 6.1.1 Button interface

“Button interface” Indicates the button function setting interface. When “Enabled” is selected, it is shown in Figure 6.1.1.

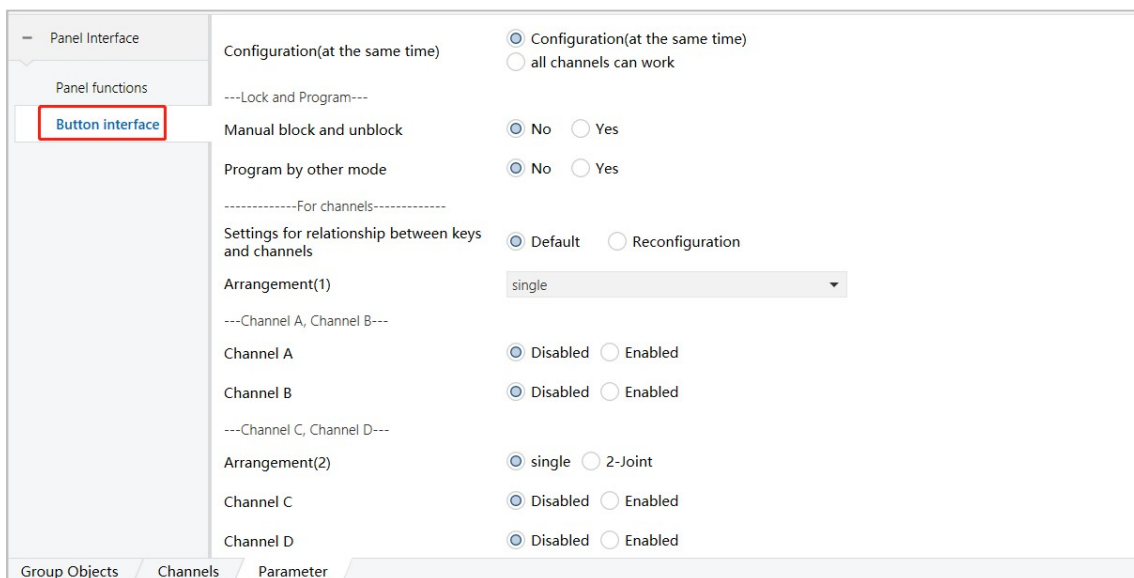

Figure 6.1.1

Parameter	Description
Configuration (at the same time)	Indicates the configuration of multiple buttons operating at the same time. Options: Configuration (at the same time)、 all channels can work ;
Manual block and unblock	Not available yet
Program by other mode	Not available yet

Settings for relationship between keys and channels	<p>Indicates the relationship between keys and channels, options are: Default, Reconfiguration; when the parameter selects "Reconfiguration", there is a parameter "Keys and channels" indicating the relationship between keys and channels, parameter "Channel X" indicates channel X (X=A, B, C...L), options are: None, Key 1, Key 2, ...Key 12. (This function is used to redefine the association between keys and channels).</p>
Arrangement(X)  (X=1~6)	<p>Indicates that multiple key channels control the same command, when a key is used, the options are: single, 2-Joint, 4-Joint;</p>
Channel X	<p>Indicates channel X, (X=A~L), here we take (X=A), parameter "Channel A" as an example to explain the relevant parameters of channel A (the following parameters are all applicable to Arrangement (X) = single, 2-Joint, 4-Joint);</p> <p><i>Note: The number of buttons on the panel corresponds to channel X. Take the 1-on-2-button panel and the 2-on-2-button panel as examples. The 1-on-2-button panel needs to open the corresponding channels "Channel A" and "Channel B", and the 2-on-2-button panel needs to open the corresponding channels Channel A, Channel B, Channel C and Channel D. The rest are similar. For details, please refer to the above "5.1 Product Operation Instructions".</i></p>
Blocking function	<p>Indicates the blocking function. This parameter is visible when "Enabled" is selected for "Channel A". The options are: Enabled, Disabled;</p>
Defined value for blocking	<p>Indicates the definition value of blocking. This parameter is visible when "Blocking function" is selected as "Enabled". The options are: blocking = 1, unblocking = 0, blocking = 0, unblocking = 1;</p>
Blocking value after voltage recovery	<p>Indicates the blocking value after voltage recovery. This parameter is visible when "Blocking function" is selected as "Enabled". The options are: unblocking, blocking, and as before voltage</p>

	failure.
Debounce time	Indicates the debounce time, the options are: 10ms, 20ms...300ms;
Select function	Indicates function selection, options include: Switching, Blind, Dimming, Scene, Value send, Multiple operation, Shift function, RGB dimming, Delay mode, Operation for local thermostat, Operation for local actuator, as shown in 6.1.1 to 6.1.11 below:

## 6.1.2 Switching

When the parameter "Select function" is set to "Switching", as shown in Figure 6.1.2

The screenshot shows a configuration window for 'Channel A'. The left sidebar has 'Channel A' selected. The main area contains the following settings:

- Blocking function:  Disabled  Enabled
- Defined value for blocking:  0=unblocking, 1=blocking  1=unblocking, 0=blocking
- Blocking value after voltage recovery: unblocking
- Debounce time: 1ms
- Select function: Switching
- Switching mode: OFF
- Status LED:  Disabled  Enabled

Figure 6.1.2

Parameter	Description
Switching mode	Indicates the switching mode. This parameter is visible when "Switching" is selected in "Select function". The options are: OFF, ON, Toggle (ON/OFF), Pressing/Releasing, Short/Long

	operation, Teleg. No.1/No.2.
Toggle value	Indicates the switching value. This parameter is visible when "Toggle (ON/OFF)" is selected in "Switching mode". The options are: According to the sent value, According to the feedback value.
Output when pressing	Indicates the output when the button is pressed. This parameter is visible when "Pressing/Releasing" is selected in "Switching mode". Options: NO, OFF, ON, Toggle (ON/OFF) to switch on and off
Output when releasing	Indicates the output when the button is released. This parameter is visible when "Pressing/Releasing" is selected in "Switching mode". The options are: NO, OFF, ON, Toggle (ON/OFF) to switch on and off;
Using another object when releasing	Indicates that the button will act on another object when it is released. This parameter is visible when "Pressing/Releasing" is selected in "Switching mode". The options are: No and Yes. When "Yes" is selected, the configuration of the parameter "Output when releasing" will be replaced.
Function of cyclic transmission	Indicates the function of cyclic transmission. This parameter is visible when "Pressing/Releasing" is selected in "Switching mode". The options are: Enabled, Disabled;
Conditions for cyclic transmission	Indicates the condition of cyclic transmission. This parameter is visible when "Enabled" is selected in "Function of cyclic transmission". The options are: If the button is pressed or the contact is on, If the button is released or the contact is off, Always;
The time of cyclic transmission :base	The base of the cyclic transmission time. This parameter is visible when "Pressing/Releasing" is selected in "Switching mode". The options are: 1s, 10s, 30s, 1min;
The time of cyclic transmission: factor	The multiplier of the cyclic transmission time. This parameter is visible when "Pressing/Releasing" is selected in "Switching mode". The options are: 0.1.2...255; (For

	<p>example: when the option of "The time of cyclic transmission:base" is: 10s, the option of "The time of cyclic transmission:factor" is: 2, then the cyclic transmission time is: 10sX2=20s);</p>
Output on short operation	<p>Indicates the output value when the button is short pressed. This parameter is visible when "Switching mode" is selected as "Short/Long operation". The options are: NO, OFF, ON, Toggle (ON/OFF) to switch on and off;</p>
Long operation time equals(base:0.1s)	<p>Indicates the time multiplier of long pressing the button. This parameter is visible when "Short/Long operation" is selected in "Switching mode". The default time base is 0.1s. Optional options: 0.1.2...255;</p>
Output on long operation	<p>Indicates the output when the button is long pressed. This parameter is visible when "Switching mode" is selected as "Short/Long operation". The options are: NO, OFF, ON, Toggle (ON/OFF) to switch on and off;</p>
Using another object on long operation	<p>Indicates that long pressing a button will act on another object. This parameter is visible when "Short/Long operation" is selected in "Switching mode". The options are: No, Yes;</p>
Value of teleg. No.1	<p>Indicates the message value of No. 1. This parameter is visible when "Switching mode" selects "Teleg. No. 1/No. 2". The options are: NO, OFF, ON, Toggle (ON/OFF) to switch on and off;</p>
Value of teleg. No.2	<p>Indicates the message value of No. 2. This parameter is visible when "Teleg. No. 1/No. 2" is selected in "Switching mode". The options are: NO, OFF, ON, Toggle (ON/OFF) to switch on and off;</p>

## 6.1.3 Blind

When the parameter

"Select function" is set to "Blind", as shown in figure 6.1.3.

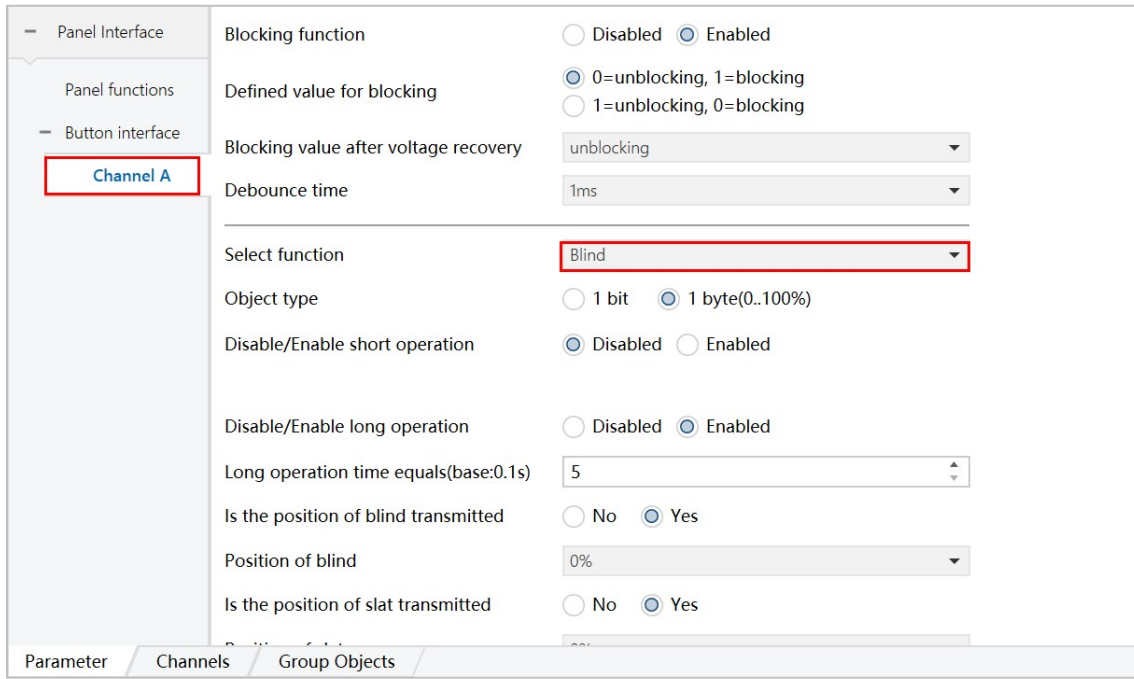

Figure 6.1.3

Parameter	Description
Object type	Indicates the object type. This parameter is visible when "Blind" is selected in "Select function". Options: 1bit, 1byte (*1..100%)
Direction of movement for short operation	Indicates the direction the curtain moves when the button is short pressed. This parameter is visible when "Object type" is set to "1bit". The options are: UP, Down, Toggle (Up/Down), Stop / Adjust Up, Stop / Adjust Down, Stop / Toggle (Adjust Up/Down).
Disable/Enable long operation	Indicates whether to disable or enable the long press operation. This parameter is visible when "Object type" is selected as "1bit". The options are: Enabled, Disabled.
Long operation time equals(base:0.1s)	Indicates the time multiplier of long pressing the button. The default time base is 0.1s. ①This parameter is visible when "Object type" is selected as "1bit" and "Disable/Enable long operation"

	<p>is selected as "Enabled". The options are: 0.1.2...255; ②This parameter is visible when "Object type" is selected as "1byte(*1..100%)" and "Disable/Enable long operation" is selected as "Enabled". The options are: 5.6.7...255</p>
<p>Direction of movement for long operation</p>	<p>Indicates the direction of movement when long pressing. This parameter is visible when "Object type" is selected as "1bit" and "Disable/Enable long operation" is selected as "Enabled". The options are: UP, Down, Toggle (Up/Down), Stop / Adjust Up, Stop / Adjust Down, Stop / Toggle (Adjust Up/Down) .</p>
<p>Send teleg. cyclically on long operation</p>	<p>Indicates sending cyclic messages through long press operation. This parameter is visible when "Object type" is selected as "1bit" and "Disable/Enable long operation" is selected as "Enabled". Options: No, Yes.</p>
<p>The interval of sending teleg. on long operation(base:0.1s)</p>	<p>Indicates the time interval for sending messages during long press operation. This parameter is visible when "Object type" is selected as "1bit" and "Send teleg. cyclically on long operation" is selected as "Yes". The default time base is 0.1s. The options are: 0.1.2...255.</p>
<p>Disable/Enable short operation</p>	<p>Indicates whether to enable or disable the short-press operation. This parameter is visible when "1byte(*1..100%)" is selected in "Object type". The options are: Enabled, Disabled.</p>
<p>Is the position of blind transmitted</p>	<p>Indicates the position of the curtain movement. ①This parameter is visible when "Object type" is selected as "1byte(*1..100%)" and "Disable/Enable short operation" is selected as "Enabled". The options are: No, Yes. ②This parameter is visible when "Object type" is selected as "1byte(*1..100%)" and "Disable/Enable long operation" is selected as "Enabled". The options are: No, Yes.</p>
<p>Position of blind</p>	<p>Indicates the position of the curtain/blind moved in each operation. This parameter is visible when "1 byte(*1..100%)" is selected for "Object type" and "Yes" is selected for "Is the position of</p>

	blind transmitted". The options are: 0%, 10%...100%;
Is the position of slat transmitted	Indicates the position of the blade rotation of each operation (blind). ①This parameter is visible when "Object type" is selected as "1byte(*1..100%)" and "Disable/Enable short operation" is selected as "Enabled". The options are: No, Yes. ②This parameter is visible when "Object type" is selected as "1byte(*1..100%)" and "Disable/Enable long operation" is selected as "Enabled".  The options are: No, Yes.
Position of slat	Indicates the position of the slat. This parameter is visible when "1byte(*1..100%)" is selected as "Object type" and "Yes" is selected as "Is the position of slat transmitted". The options are: 0%, 10%...100%.
Disable/Enable long operation	Indicates whether to disable or enable the long press operation. This parameter is visible when "Object type" is selected as "1byte(*1..100%)". The options are: Enabled, Disabled.

## 6.1.4 Dimming

When the parameter "Select function" is set to "Dimming", as shown in Figure 6.1.4.

The screenshot shows a configuration window for 'Channel A'. The left sidebar lists 'Panel Interface', 'Panel functions', and 'Button interface', with 'Channel A' selected. The main area displays various settings:

- Blocking function:  Disabled  Enabled
- Defined value for blocking:  0=unblocking, 1=blocking  1=unblocking, 0=blocking
- Blocking value after voltage recovery: unblocking
- Debounce time: 1ms
- Select function: **Dimming** (highlighted with a red box)
- Dimming type:  Relative dimming  Absolute dimming
- Disable/Enable short operation:  Disabled  Enabled
- Percentage of dimming: 0%
- Disable/Enable long operation:  Disabled  Enabled
- Long operation time equals(base:0.1s): 5
- Percentage of dimming: 0%
- Status LED:  Disabled  Enabled

At the bottom, there are tabs for 'Parameter', 'Channels', and 'Group Objects'.

Figure 6.1.4

Parameter	Description
Dimming type	Indicates the dimming type. This parameter is visible when "Dimming" is selected in "Select function". The options are: Relative dimming and Absolute dimming;
Switching direction on short operation	Indicates that the switch is controlled by short pressing. This parameter is visible when "Relative dimming" is selected in "Dimming type". The options are: OFF, ON, Toggle (ON/OFF) to switch on and off;
Toggle value	Indicates the switching value. This parameter is visible when "Toggle (ON/OFF)" is selected in "Switching direction on short operation". The options are: According to the sent value, according to the sent value;
Read status object at voltage recovery	Indicates the function of reading the object status after the voltage is restored. This parameter is visible when "According to the sent value" is selected in "Toggle value". The options are: No, Yes.
Disable/Enable short operation	Indicates whether to disable or enable short-press operation. This parameter is visible when "Absolute dimming" is selected in "Dimming type". The options are: Disabled, Enabled;
Disable/Enable long operation	Indicates whether to disable or enable the long press operation. The options are: Disabled, Enabled;
Long operation time equals(base:0.1s)	Indicates the time of long press operation. This parameter is visible when "Disable/Enable long operation" is selected as "Enabled". The default time base is 0.1s. The options are: 5.6.7...255;
Dimming direction on long operation	Indicates that the dimming direction is controlled by long pressing. This parameter is visible when "Disable/Enable long operation" is selected as "Enabled" or "Absolute dimming" is selected as

	"Dimming type". The options are: Darker, Brighter, Toggle (Darker/Brighter);
Step dimming(Darker)	Indicates setting step dimming. This parameter is visible when "Darker" is selected in "Dimming direction on long operation". The options are: To min. Brightness, 1/2 darker, 1/4 darker...1/64 darker;
Step dimming (Brighter)	Indicates setting step dimming (Brighter). This parameter is visible when "Brighter" is selected in "Dimming direction on long operation" or "Toggle (Darker/Brighter)" is selected. The options are: To max. Brightness, 1/2 Brighter), 1/4 Brighter...1/64 Brighter;
Step dimming (Darker)	Indicates setting step dimming (darkening). This parameter is visible when "Darker" is selected in "Dimming direction on long operation" or "Toggle (Darker/Brighter)" is selected. The options are: To min. Brightness, 1/2 darker, 1/4 darker...1/64 darker;
Send dimming levels cyclically	Indicates sending dimming brightness in a loop, options: No, Yes;
The interval of sending teleg. (base:0.1s)	Indicates the interval time for sending messages. The default time base is 0.1s. This parameter is visible when "Send dimming levels cyclically" is selected as "Yes". The options are: 0.1.2...255.
Send stop teleg. after releasing	Indicates that a stop command message is sent after the button is released after long pressing. This parameter is visible when "Send dimming levels cyclically" is selected as "Yes". The options are: No, Yes.
Percentage of dimming	Indicates the dimming percentage. This parameter is visible when "Absolute dimming" is selected for "Dimming type" and "Enabled" is selected for "Disable/Enable short operation". The options are: 0%, 10%...100%;
Long operation time equals(base:0.1s )	Indicates the time of long press operation. The default time base is 0.1s. This parameter is visible when "Absolute dimming" is selected for "Dimming type" and "Enabled" is selected for

	"Disable/Enable long operation". The options are: 5.6.7...255;
Percentage of dimming	Indicates the dimming percentage. This parameter is visible when "Absolute dimming" is selected for "Dimming type" and "Enabled" is selected for "Disable/Enable long operation". The available options are: 0%, 10%...100%.

## 6.1.5 Scene

When the parameter "Select function" is selected as "Scene", it is shown as Figure 6.1.5.

The screenshot shows the configuration interface for Channel A. The left sidebar has 'Channel A' selected. The main area displays the following settings:

- Blocking function:  Disabled  Enabled
- Defined value for blocking:  0=unblocking, 1=blocking  1=unblocking, 0=blocking
- Blocking value after voltage recovery: unblocking
- Debounce time: 1ms
- Select function: **Scene** (highlighted with a red box)
- Direct action on short operation:  Sends scene 1  Toggle(scene 1/scene 2)
- scene 1 number is: Scene NO.1
- scene 2 number is: Scene NO.1
- Disable/Enable long operation:  Disabled  Enabled
- Long operation time equals(base:0.1s): 5
- Function of long operation:  Recall scene  Program scene
- scene number is: Scene NO.1

Figure6.1.5

Parameter	Description
Direct action on short operation	Indicates that a command is executed by a short press. This parameter is visible when "scene" is selected in "Select function". The options are: Sends scene 1, Toggle (scene 1/scene 2);
Scene 1 number is	Indicates the scene number corresponding to scene 1, options: Scene NO.1, Scene NO.2...Scene NO.64;

Scene 2 number is	Indicates the scene number corresponding to scene 2, this parameter is visible when "Direct action on short operation" selects Toggle (scene 1/scene 2), options: Scene NO.1, Scene NO.2...Scene NO.64;
Disable/Enable long operation	Indicates whether to disable or enable the long press operation. The options are: Disabled, Enabled;
Long operation time equals(base:0.1s )	Indicates the time of long press operation. The default time base is 0.1s. This parameter is visible when "Disable/Enable long operation" is selected as "Enabled". The options are: 5.6.7...255;
Function of long operation	Indicates the function of long press operation. This parameter is visible when "Disable/Enable long operation" is selected as "Enabled". The options are: Recall scene, Program scene;
Scene number is	Indicates the set (called) scene number. This parameter is visible when "Disable/Enable long operation" is selected as "Enabled". The options are: Scene NO.1, Scene NO.2...Scene NO.64.

## 6.1.6 Value send

When the parameter "Select function" is set to "Value send", as shown in Figure 6.1.6.

The screenshot shows the configuration window for 'Channel A' in the Light Control software. The interface is divided into a left sidebar and a main configuration area. The sidebar includes 'Panel Interface', 'Panel functions', and 'Button interface', with 'Channel A' selected under 'Button interface'. The main area contains various settings:

- Blocking function:** Radio buttons for 'Disabled' and 'Enabled' (selected).
- Defined value for blocking:** Radio buttons for '0=unlocking, 1=blocking' (selected) and '1=unlocking, 0=blocking'.
- Blocking value after voltage recovery:** A dropdown menu set to 'unlocking'.
- Debounce time:** A dropdown menu set to '1ms'.
- Select function:** A dropdown menu set to 'Value send' (highlighted with a red box).
- The mode for value sending:** A dropdown menu set to 'Short/Long operation'.
- Output on short operation:** Radio buttons for 'No' (selected) and 'Yes'.
- Long operation time equals(base:0.1s):** A numeric input field set to '5'.
- Output on long operation:** Radio buttons for 'No' and 'Yes' (selected).
- Output mode on long operation:** Radio buttons for 'Output value 1' (selected) and 'Toggle(value 1/value 2)'.
- the type of output value 1:** A dropdown menu set to '1 bit value[0..1]'.
- Output value[0..1]:** A numeric input field set to '0'.

At the bottom, there are tabs for 'Parameter', 'Channels', and 'Group Objects'.

Figure 6.1.6

Parameter	Description
The mode for value sending	Indicates the value sending operation. This parameter is visible when "Value send" is selected in "Select function". The options are: Value sending for teleg. No.1/No.2, Pressing/Releasing, Short/Long operation;
Value sending for teleg. No.1	Indicates the value sending of message No.1. This parameter is visible when "Value sending for teleg. No.1/No.2" is selected in "The mode for value sending". The options are: Disabled, Enabled.
Output mode for value of teleg. No.1	Indicates the output operation of message No.1. This parameter is visible when "Value sending for teleg. No.1/No.2" is selected in "The mode for value sending" and "Enabled" is selected in "Value sending for teleg. No.1". The options are: Output value 1, Toggle (value 1/value 2);
the type of output value 1	Indicates the type of output value 1. This parameter is visible when "Value sending for

	<p>teleg. No.1/No.2" is selected in "The mode for value sending" and "Output value 1" is selected in "Output mode for value of teleg. No.1" or "Toggle (value 1/value 2)" is selected.</p> <p>The options are: 1 bit value [0..1], 4 bit value [0..15], 1 byte value [0..255], 2 byte value [0..65535];</p>
the type of output value 2	<p>Indicates the type of output value 2. This parameter is visible when "Value sending for teleg. No.1/No.2" is selected in "The mode for value sending" and "Toggle(value 1/value 2)" is selected in "Output mode for value of teleg. No.1". The options are: 1 bit value[0..1], 4 bit value[0..15], 1 byte value[0..255], 2 byte value[0..65535];</p>
Output value[0..1]	<p>Indicates the output value. This parameter is visible when "1 bit value[0..1]" is selected in "the type of output value 1" or "the type of output value 2". The options are: 0, 1.</p>
Output value[0..15]	<p>Indicates the output value. This parameter is visible when "4 bit value[0..15]" is selected in "the type of output value 1" or "the type of output value 2". The options are: 0, 1, 2...15;</p>
Output value[0..255]	<p>Indicates the output value. This parameter is visible when "the type of output value 1" or "the type of output value 2" selects "1 byte value [0..255]". The options are: 0, 1, 2...255;</p>
Output value[0..255]	<p>Indicates the output value. This parameter is visible when "2 byte value [0..65535]" is selected in "the type of output value 1" or "the type of output value 2". The options are: 0, 1, 2...65535;</p>
Output when pressing	<p>Indicates the output when the button is pressed. This parameter is visible when "Pressing/Releasing" is selected in "The mode for value sending". The options are: No, Yes;</p>
Output type when releasing	<p>Indicates the output type when the button is pressed. This parameter is visible when "Pressing/Releasing" is selected for "The mode for value sending" and "Yes" is selected</p>

	for "Output when pressing". The options are: 1 bit value[0..1], 4 bit value[0..15], 1 byte value[0..255], 2 byte value[0..65535];
Output when releasing	Indicates output when the key is released. This parameter is visible when "Pressing/Releasing" is selected in "The mode for value sending". Options: No, Yes
Output type when releasing	Indicates the output type when the button is released. This parameter is visible when "Yes" is selected for "Output when releasing". The options are: 1 bit value [0..1], 4 bit value [0..15], 1 byte value [0..255], 2 byte value [0..65535]
Function of cyclic transmission	Indicates the function of cyclic transmission. This parameter is visible when "Pressing/Releasing" is selected in "The mode for value sending". The options are: Disabled, Enabled;
Conditions for cyclic transmission	Indicates the condition of cyclic transmission. This parameter is visible when "Enabled" is selected in "Function of cyclic transmission". The options are: If the button is pressed or the contact is on, If the button is pressed or the contact is off, Always;
The time of cyclic transmission: base	Indicates the base of cyclic transmission time. This parameter is visible when "Function of cyclic transmission" is selected as "Enabled". The options are: 1s, 10s, 30s, 1min;
The time of cyclic transmission: factor	The multiplier of the cyclic transmission time. This parameter is visible when "Function of cyclic transmission" is selected as "Enabled". The options are: 0.1.2...255; (For example: when the option of "The time of cyclic transmission: base" is: 10s, the option of "The time of cyclic transmission: factor" is: 2, then the cyclic transmission time is: 10sX2=20s);
Output on short operation	Indicates the output value when the button is short pressed. This parameter is visible when "Short/Long operation" is selected in "The mode for value sending". The options are: No, Yes;

Output mode on short operation	Indicates the output mode of short-press operation. This parameter is visible when "The mode for value sending" is selected as "Short/Long operation" and "Output on short operation" is selected as "Yes". The options are: Output value 1, Toggle (value 1/value 2);
the type of output value 1	Indicates the type of output value 1. This parameter is visible when "Short/Long operation" is selected for "The mode for value sending" and "Output value 1" is selected for "Output mode on short operation" or "Toggle (value 1/value 2)" is selected. The options are: 1 bit value [0..1], 4 bit value [0..15], 1 byte value [0..255], 2 byte value [0..65535];
the type of output value 2	Indicates the type of output value 2. This parameter is visible when "The mode for value sending" is selected as "Short/Long operation" and "Output mode on short operation" is selected as "Toggle (value 1/value 2)". The options are: 1 bit value [0..1], 4 bit value [0..15], 1 byte value [0..255], 2 byte value [0..65535];
Long operation time equals(base:0.1s)	Indicates the time multiplier of long pressing the button. The default time base is 0.1s. This parameter is visible when "Short/Long operation" is selected in "The mode for value sending". The options are: 0.1.2...255;
Output on long operation	Indicates the output when the button is long pressed. This parameter is visible when "Short/Long operation" is selected in "The mode for value sending". The options are: NO (disabled), Yes (enabled);
Output mode on long operation	Indicates the output mode of the long press operation. This parameter is visible when "The mode for value sending" is selected as "Short/Long operation" and "Output on long operation" is selected as "Yes". The options are: Output value 1, Toggle (value 1/value 2);

## 6.1.7 Multiple operation

When the parameter "Select function" selects "Multiple operation", it is shown as Figure 6.1.7.

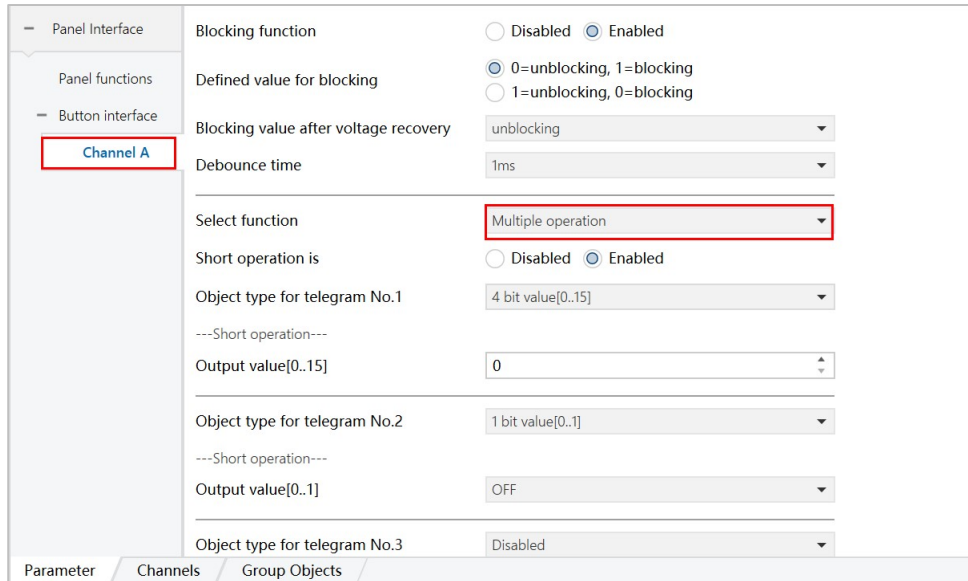

Figure 6.1.7

Parameter	Description
Short operation is	Indicates the function of setting the short press operation. This parameter is visible when "Multiple operations" is selected in "Select function". The options are: Disabled, Enabled;
Object type for telegram No.X	Indicates the object type controlled by message X (X=1~4). This parameter is visible when "Short operation is" is selected as "Enabled". The options are: Disabled, 1 bit value [0..1], 4 bit value [0..15], 1 byte value [0..255], 2 byte value [0..65535] (Note: When the parameter "Object type for telegram No.X" is not selected as "Disabled", press the button to send message No.X. A maximum of 4 messages can be sent at the same time);
Output value[0..1]	Indicates the output value of (short press/long press). ①When "1 bit value[0..1]" is selected in "Object type for telegram No.X", the options are: OFF, ON, Toggle (ON/OFF) to switch on and off; ②When "4 bit value[0..15]" is selected, the options are: 0, 1, 2...15; ③When "1 byte value[0..255]" is selected, the options are: 0, 1, 2...255; ④When "2 byte value[0..65535]" is selected, the options are: 0, 1, 2...65535; (Note: To set the long press output value, you need to select Enabled in the parameter "Long operation is" in advance);

Long operation is	Indicates the function of setting the long press operation. This parameter is visible when "Short operation is" selects "Enabled". Options: Disabled, Enabled;
Long operation time equals(base:0.1s)	Indicates the time multiplier of long pressing the button. The default time base is 0.1s. This parameter is visible when "Long operation is" is selected as "Enabled". The options are: 5.6.7...255;

## 6.1.8 Shift function

When the parameter "Select function" is selected as "Shift function", it is shown as Figure 6.1.8.

Figure 6.1.8

Parameter	Description
Shift type	Shift type. This parameter is visible when "Shift function" is selected in "Select function". The options are: Shift by step value, Shift by setting value, Shift by object;
Object type	Object type. This parameter is visible when "Shift by step value" is selected in "Shift type". The

	options are: 1byte unsigned value, 2byte unsigned value, 2byte float value.
Amplification for unsigned value	Indicates to enlarge the unsigned value. This parameter is visible when "Shift type" is selected as "Shift by step value" and "Object type" is selected as "2 byte unsigned value". The options are: x1, x10, x100;
Amplification for float value	Indicates to enlarge the floating value. This parameter is visible when "Shift type" is selected as "Shift by setting value" and "Object type" is selected as "2 byte float value". The options are: x1, x10, x100;
Number of values	Indicates the size of the shift value. This parameter is visible when "Shift type" selects "Shift by setting value" or "Shift by object". The options are: 1, 2, 3...10;
Object values	Indicates the value of the object. This parameter is visible when "Shift type" selects "Shift by object". The options are: OFF, ON, Toggle (ON/OFF) to switch between on and off.
--Begin with value 1-- Output value[0..255]	Indicates the starting value 1 used to set the displacement. This parameter is visible when "Shift type" selects "Shift by step value". The options are: 0.1.2...255;
--End with value 2-- Output value[0..255]	Indicates the end value 2 used to set the displacement. This parameter is visible when "Shift by step value" is selected in "Shift type". The options are: 0.1.2...255;
--The step size-- Step value	Indicates the step value (of one step). This parameter is visible when "Shift type" is selected as "Shift by step value". The options are: 0.1.2...255;
--Default value-- Output value[0..255]	Indicates the output default value. This parameter is visible when "Shift type" selects "Shift by step value". The options are: 0.1.2...255;
Status feedback object	Indicates the state of the feedback object, options: Disabled, Enabled;
Read status object at voltage recovery	Indicates the state of voltage recovery of the reading object. This parameter is visible when "Enabled" is selected in "Status feedback object". The options are: NO, Yes.

Direction	Indicates the direction of the shift, options: From value 1 to value 2, From value 2 to value 1.  (This parameter is also visible when "Shift by object" is selected in "Shift type", options: From lowest to highest, From highest to lowest;)
Default object	This indicates setting the default object. This parameter is visible when "Shift by object" is selected in "Shift type". The options are: object 1, object 2, object 3, object 4;
Shift circularly for value	Indicates the value of the circular shift, options: NO, Yes;
Reset function	Indicates the reset function of the shift, options: Disabled, Enabled by long operation;
Reaction when pressing	Indicates whether to perform a shift operation when the setting button is pressed. This parameter is visible when "Disabled" is selected in "Reset function". The options are: NO, Yes;
Reaction when releasing	Indicates whether to perform a shift operation when the setting button is released. This parameter is visible when "Disabled" is selected in "Reset function". The options are: NO, Yes;
Long operation time equals(base:0.1s)	Indicates the time multiplier for long pressing a button. The default time base is 0.1s. This parameter is visible when "Enabled by long operation" is selected in "Reset function". Optional options: 5.6.7...255.

## 6.1.9 RGB dimming

When the parameter "Select function" selects "RGB dimming", it is shown as Figure 6.1.9.

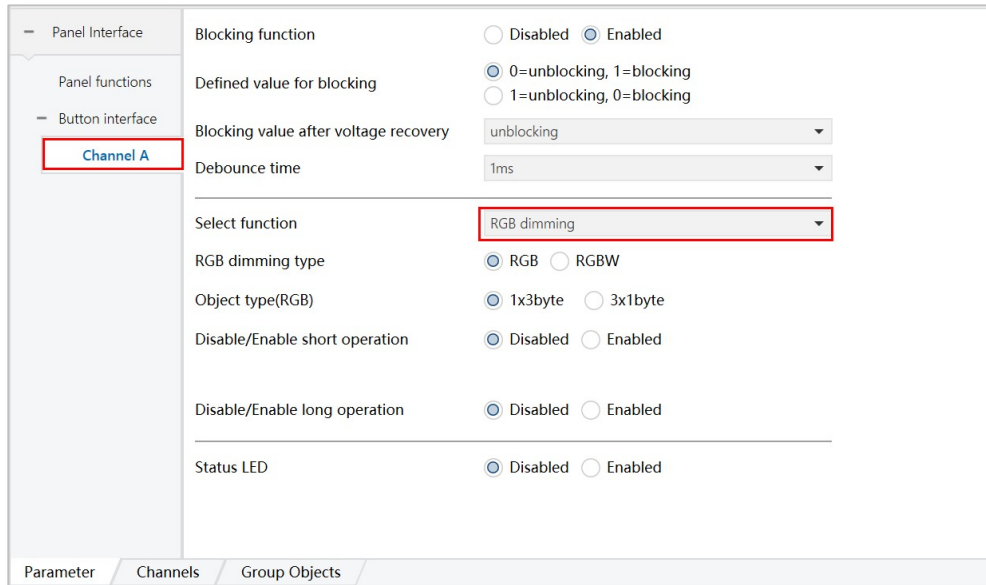

Figure 6.1.9

Parameter	Description
RGB dimming type	RGB dimming mode. This parameter is visible when "RGB dimming" is selected in "Select function". The options are: RGB, RGBW;
Object type(RGB)	Indicates the object type of RGB. ①This parameter is visible when "RGB dimming" is selected as "RGB". The options are: 1x3byte, 3x1byte; ②This parameter is also visible when "RGBW" is selected as "RGB dimming". The options are: 1x6byte, 4x1byte;
Disable/Enable short operation	Indicates disabling or enabling the short press operation, options: Disabled, Enabled;
Disable/Enable long operation	Indicates disabling or enabling the long press operation, options: Disabled, Enabled;
Long operation time equals(base:0.1s)	Indicates the time multiplier of long pressing the button. The default time base is 0.1s. Optional items: Optional items: 5.6.7...255;
--Red value- Output value[0..255]	Indicates the output value of red. ①This parameter is visible when "Disable/Enable short operation" is selected as "Enabled". The options are: 0.1.2...255; ②This parameter is visible

	when "Disable/Enable long operation" is selected as "Enabled". The options are: 0.1.2...255;
--Green value- Output value[0..255]	Indicates the output value of green. ①This parameter is visible when "Disable/Enable short operation" is selected as "Enabled". The options are: 0.1.2...255. ②This parameter is visible when "Disable/Enable long operation" is selected as "Enabled". The options are: 0.1.2...255.
--Blue value- Output value[0..255]	Indicates the output value of blue. ①This parameter is visible when "Disable/Enable short operation" is selected as "Enabled". The options are: 0.1.2...255; ②This parameter is visible when "Disable/Enable long operation" is selected as "Enabled". The options are: 0.1.2...255;

### 6.1.10 Delay mode

When the parameter "Select function" is set to "Delay mode", it will be shown as Figure 6.1.10.

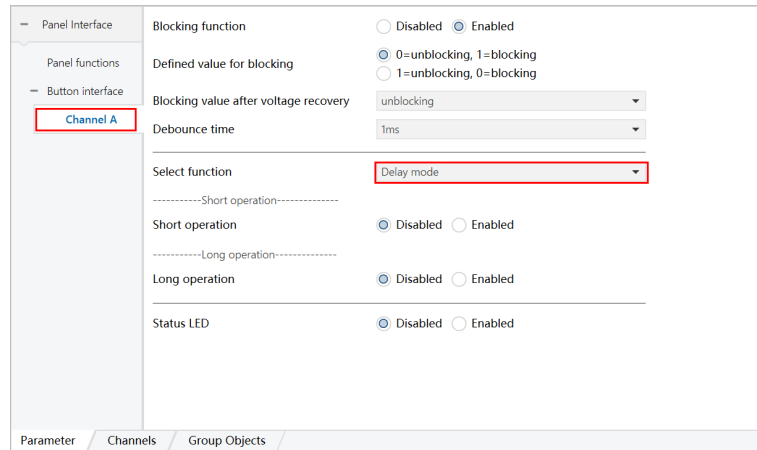

Figure 6.1.10

Parameter	Description
Short operation	Short operation. This parameter is visible when "Delay mode" is selected in "Select function". The options are: Disabled, Enabled.
Long operation	Long press operation. This parameter is visible when "Delay mode" is selected in "Select function". The options are: Disabled and Enabled.

the type of output value 1	Indicates the output type of value 1. This parameter is visible when "Short operation" is selected as "Enabled" or "Long operation" is selected as "Enabled". The options are: 1 bit value [0..1], 4 bit value [0..15], 1 byte value [0..255], 2 byte value [0..65535];
the type of output value 2	Indicates the output type of value 2. This parameter is visible when "Short operation" is selected as "Enabled" or "Long operation" is selected as "Enabled". The options are: 1 bit value [0..1], 4 bit value [0..15], 1 byte value [0..255], 2 byte value [0..65535];
Output value[0..1]	Indicates the output value of (short press/long press). ① When the parameter selects "1 bit value [0..1]", the options are: OFF, ON, Toggle (ON/OFF) to switch between on and off; ② When selecting "4 bit value [0..15]", the options are: 0, 1, 2...15; ③ When selecting "1 byte value [0..255]", the options are: 0, 1, 2...255; ④ When selecting "2 byte value [0..65535]", the options are: 0, 1, 2...65535;
Send mode	Send mode. This parameter is visible when "Enabled" is selected for "Short operation" or "Enabled" is selected for "Long operation". The options are: No action when pressing, send value 1 after..., Send value 1 when pressing, send value 2 a..;
Delay time(base)	The base of the delay time. This parameter is visible when "Short operation" is selected as "Enabled" or "Long operation" is selected as "Enabled". The options are: 1s, 30s, 1min;
Delay time(factor)	Delay time multiplier. This parameter is visible when "Short operation" selects "Enabled" or "Long operation" selects "Enabled". The options are: 0, 1, 2...255.

## 6.1.11 Operation for local thermostat

When the parameter "Select function" is selected as "Operation for local thermostat", it is shown as Figure 6.1.11.

The screenshot shows the configuration interface for 'Channel A'. The left sidebar has 'Channel A' selected. The main area contains the following settings:

- Blocking function:**  Disabled  Enabled
- Defined value for blocking:**  0=unblocking, 1=blocking  1=unblocking, 0=blocking
- Blocking value after voltage recovery:** unblocking
- Debounce time:** 1ms
- Select function:** Operation for local thermostat (highlighted with a red box)
- Operation function:** Switching
- Operation direction:** Off
- Disable/Enable long operation:**  Disabled  Enabled
- Long operation time equals(base:0.1s):** 5
- Operation function (second instance):** Switching
- Operation direction (second instance):** Off
- Status LED:**  Disabled  Enabled

At the bottom, there are tabs for 'Parameter', 'Channels', and 'Group Objects'.

Figure 6.1.11

Parameter	Description
Operation function	Operation function, indicating the object of operation. This parameter is visible when "Operation for local thermostat" is selected in "Select function" or "Enabled" is selected in "Disable/Enable long operation". The options are: Switching, Mode, Fan speed, Setting temperature, Page switching, Heat/cool.
Operation direction	Operation direction, indicating the object of the operation. This parameter is visible when "Operation for local thermostat" is selected in "Select function" or "Enabled" is selected in "Disable/Enable long operation". The options are: OFF, ON, Toggle.
Disable/Enable long operation	Indicates disabling or enabling the long press operation, options: Disabled, Enabled;
Long operation time equals(base:0.1s)	Indicates the time multiplier for long pressing a button. This parameter is visible when "Disable/Enable long operation" is selected as "Enabled". The default time base is 0.1s. Optional items: Optional items: 5.6.7...255.

6.1.12 Operation for local actuator—**Not available**

6.1.13 Status LED

When the parameter "Status LED" is set to "Enabled", as shown in Figure 6.1.12.

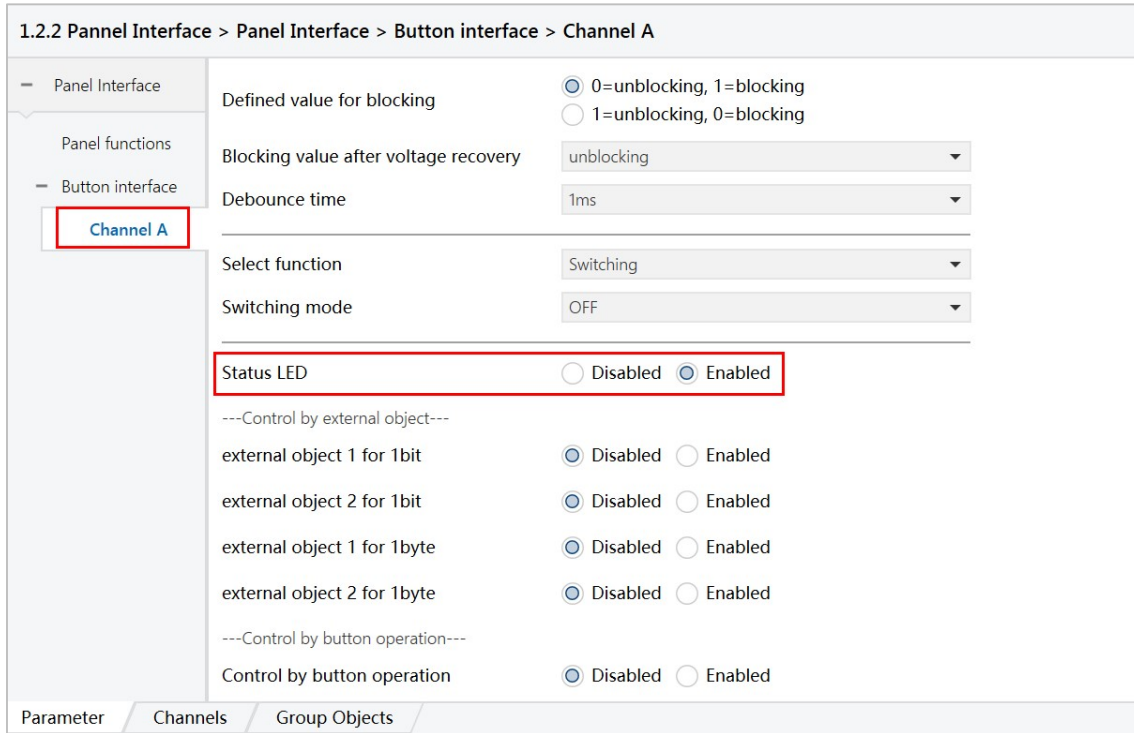

Figure 6.1.12

Parameter	Description
Status LED	Indicates the status of the button LED, options: Disabled, Enabled;
external object X for 1bit	Indicates 1-bit external object X (X=1, 2). This parameter is visible when "Enabled" is selected in "Status LED". The options are: Disabled, Enabled.
LED colour of value = '0' for 1bit	The color of the LED when '0' is a 1-bit value. This parameter is visible when "Enabled" is selected for "external object X (X=1, 2) for 1bit". The options are: Off, On, Red, Magenta, Orange, Green, Cyan, Blue, White;  (Note: except for "Off" and "On", the other options are not available)

<p>LED colour of value = '1' for 1bit</p>	<p>The color of the LED when '1' is a 1-bit value. This parameter is visible when "Enabled" is selected in "external object X(X=1, 2) for 1bit". The options are: Off, On, Red, Magenta, Orange, Green, Cyan, Blue, White;</p> <p>(Note: except for "Off" and "On", the other options are not available)</p>
<p>Read status object at voltage recovery (1bit object X)</p>	<p>The state after voltage recovery when the read object X (X=1, 2) is 1 bit in size; this parameter is visible when "external object X for 1bit" is selected as "Enabled", and the options are: NO, Yes;</p>
<p>external object X for 1byte</p>	<p>Indicates an external object X (X=1, 2) of 1 byte in size. This parameter is visible when "Enabled" is selected in "Status LED". The options are: Disabled, Enabled.</p>
<p>Threshold Y is</p>	<p>Indicates setting the threshold Y ((Y=1~5). This parameter is visible when "external object X(X=1, 2) for 1byte" is selected as "Enabled" or "Threshold Y" is selected as "Enabled". The options are: 0, 1, 2...255;</p>
<p>Logical conditions of object and threshold Y</p>	<p>Logical condition of object and threshold Y ((Y=1~5). This parameter is visible when "external object X(X=1, 2) for 1byte" is selected as "Enabled" or "Threshold Y" is selected as "Enabled".</p> <p>The options are: Object value &gt;= threshold Y, Object value = threshold Y, Object value &lt;= threshold Y, Object value != threshold Y;</p>
<p>Satisfy the condition of threshold Y, the LED is</p>	<p>Indicates the state of the LED when the setting meets the threshold Y ((Y=1~5) condition; this parameter is visible when "external object X(X=1, 2) for 1byte" is selected as "Enabled" or "Threshold Y" is selected as "Enabled", and the options are: Off, On, Red, Magenta, Orange, Green, Cyan, Blue, White.</p> <p>(Note: except for "Off" and "On", the other options are not available)</p>
<p>Threshold Y</p>	<p>Indicates the threshold value Y ((Y=1~5). This parameter is visible when "Enabled" is selected for</p>

	"external object X (X=1, 2)for 1byte". The options are: Disabled and Enabled.
Read status object at voltage recovery (1byte object X)	The state after voltage recovery when the read object X (X=1, 2) is 1 byte in size; this parameter is visible when "external object X for 1bit" is selected as "Enabled", and the options are: NO, Yes;
Control by button operation	Indicates control through button operation, options: Disabled, Enabled;
Triggering of status LED	Indicates the LED status after triggering. This parameter is visible when "Enabled" is selected in "Control by button operation". The options are: Always LED 1, LED 1 flashes, Pressing = LED 1/Releasing = LED 2, Short operation = LED 1/ Long operation = LED 2, LED 1 flashes three times, then LED 2;
LED 1 equals	Indicates setting the function status of LED1. This parameter is visible when "Enabled" is selected in "Control by button operation". The options are: Off, On, Red, Magenta, Orange, Green, Cyan, Blue, White;  (Note: except for "Off" and "On", the other options are not available)
LED 2 equals	Indicates setting the function status of LED2. This parameter is visible when "Enabled" is selected in "Control by button operation". The options are: Off, On, Red, Magenta, Orange, Green, Cyan, Blue, and White.  (Note: Except for "Off" and "On", the remaining options are not available.)

### 6.1.13 LED settings

The parameter "LED settings" indicates the settings of LED. The options are: Disabled, Enabled. When "Enabled" is

selected, the following red boxes are shown in Figure 6.1.13 and Figure 6.1.14.

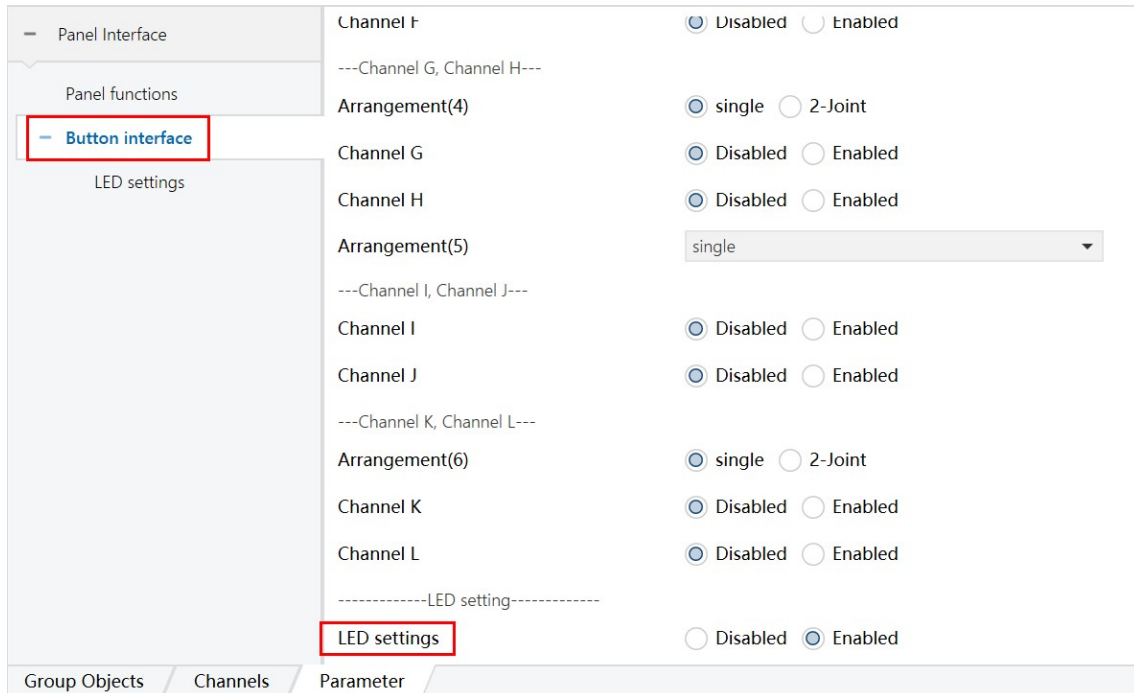

Figure 6.1.7

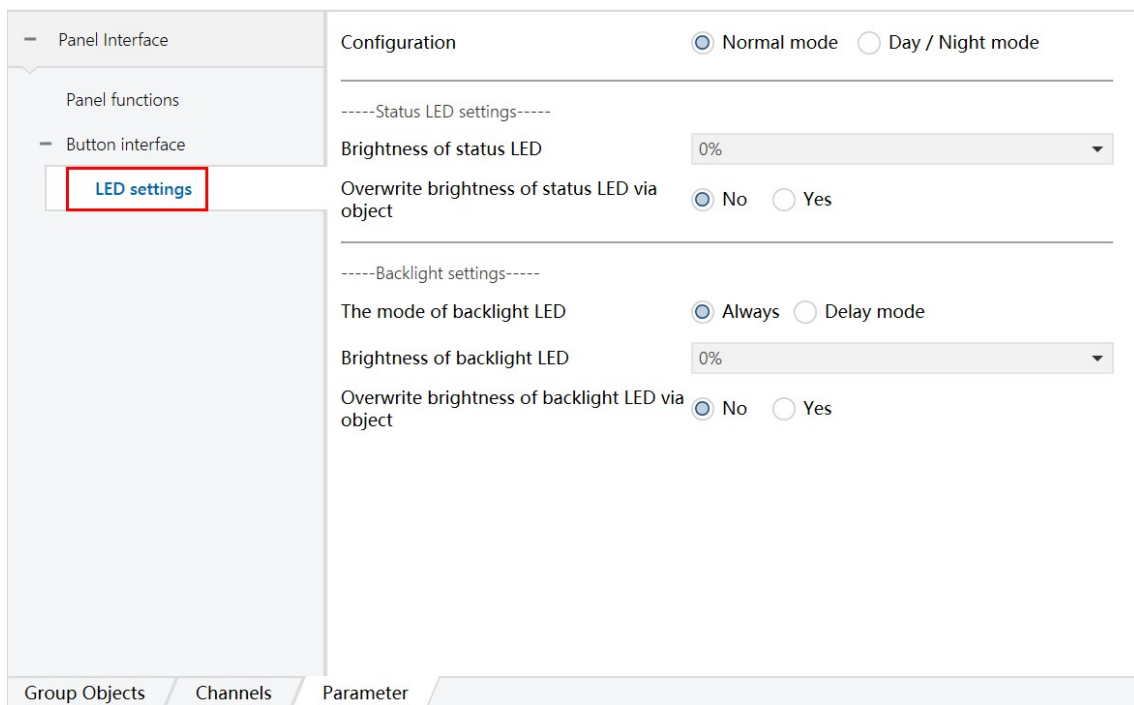

Figure6.1.8

Parameter	Description
LED settings	LED settings, options: Disabled, Enabled;

Configuration	Configuration mode, options: Normal mode, Day / Night mode;
Brightness of status LED	Set the brightness of the LED. This parameter is visible when "Normal mode" is selected in "Configuration". The options are: 0%, 1%...100%;
Overwrite brightness of status LED via object	Indicates that the brightness of the status LED is overwritten by the object. This parameter is visible when "Normal mode" is selected in "Configuration". The options are: NO (disabled), Yes (enabled);
Polarity of Day/Night mode	Polarity of day/night mode. This parameter is visible when "Day / Night mode" is selected in "Configuration". The options are: Day=1, Night=0, Day=0, Night=1;
Read Day/Night mode at voltage recovery	Read the day/night mode when the voltage is restored. This parameter is visible when "Day / Night mode" is selected in "Configuration". The options are: NO (disabled), Yes (enabled);
( --In the day-- ) Brightness of status LED	During the day, set the brightness of the LED. This parameter is visible when "Day / Night mode" is selected in "Configuration". The options are: 0%, 1%...100%;
( --In the day-- ) Overwrite brightness of status LED via object	During the day, the brightness of the status LED is overwritten by the object. This parameter is visible when "Day / Night mode" is selected in "Configuration". The options are: NO (disabled), Yes (enabled);
( --At night-- ) Brightness of status LED	At night, set the brightness of the LED. This parameter is visible when "Day / Night mode" is selected in "Configuration". The options are: 0%, 1%...100%;
( --At night-- ) Overwrite brightness of status LED via object	At night, the brightness of the status LED is overwritten by the object. This parameter is visible when "Day / Night mode" is selected in "Configuration". The options are: NO (disabled), Yes (enabled);
The mode of backlight LED	Indicates setting the LED backlight mode, options: Always, Delay mode;
Brightness of backlight	Indicates setting the brightness of the LED backlight. This parameter is visible when "Always"

LED	is selected in "The mode of backlight LED". The options are: 0%, 1%...100%. ;
Overwrite brightness of backlight LED via object	Indicates that the brightness of the backlight LED is rewritten through the object. This parameter is visible when "Always" is selected in "The mode of backlight LED". The options are: NO (disabled), Yes (enabled);
Delay time after waking backlight	The delay time of the backlight turning off after being awakened. This parameter is visible when "Delay mode" is selected in "The mode of backlight LED". The options are: delay according to master device, delay according to radar or IR, 1seconds, 2seconds...120minutes;
Whether status LED is related	Whether to associate the LED status light. This parameter is visible when "The mode of backlight LED" is selected as "Delay mode". The options are: NO (disabled), Yes (enabled);
Master output for controlling other's backlight	As the master device, it sends switch information to control the backlight of other slave panel devices. This parameter is visible when "The mode of backlight LED" is selected as "Delay mode". The options are: NO (disabled), Yes (enabled);
Wake up backlight by button	Use the button to wake up the backlight. This parameter is visible when "Delay mode" is selected in "The mode of backlight LED". The options are: NO (disabled), Yes (enabled);
Wake up backlight by sensor(radar, IR.....)	Use radar or infrared to wake up the backlight. This parameter is visible when "The mode of backlight LED" is selected as "Delay mode". The options are: NO (disabled), Yes (enabled);
Wake up backlight via object	Wake up the backlight through the sensor (radar, infrared). This parameter is visible when "The mode of backlight LED" is selected as "Delay mode". The options are: NO (disabled), Yes (enabled);
Time to detect sensor circularly for output	The time for the sensor to cycle and detect the output. This parameter is visible when "Delay mode" is selected for "The mode of backlight LED" and "Yes" is selected for "Wake up backlight via object". The options are: only once when triggered, 1 seconds, 2 seconds, ... 15

	seconds;
The triggering value for waking backlight	The trigger value for waking up the backlight. This parameter is visible when "Delay mode" is selected for "The mode of backlight LED" and "Yes" is selected for "Wake up backlight via object". The options are: Off is triggering value, On is triggering value;
Output triggering signal for waking backlight	Use the output trigger signal to wake up the backlight. This parameter is visible when "The mode of backlight LED" is selected as "Delay mode". The options are: NO (disabled), Yes (enabled);
The triggering value for output	Triggering of output value. This parameter is visible when "Delay mode" is selected in "The mode of backlight LED" and "Yes" is selected in "Output triggering signal for waking backlight".  The options are: Off is triggering value, On is triggering value.

## 6.2 Parameter setting interface-Mixed Thermostat

The parameter "Mixed Thermostat" indicates the thermostat function setting interface, when "Enabled" is selected, as shown in Figure 6.2.0.

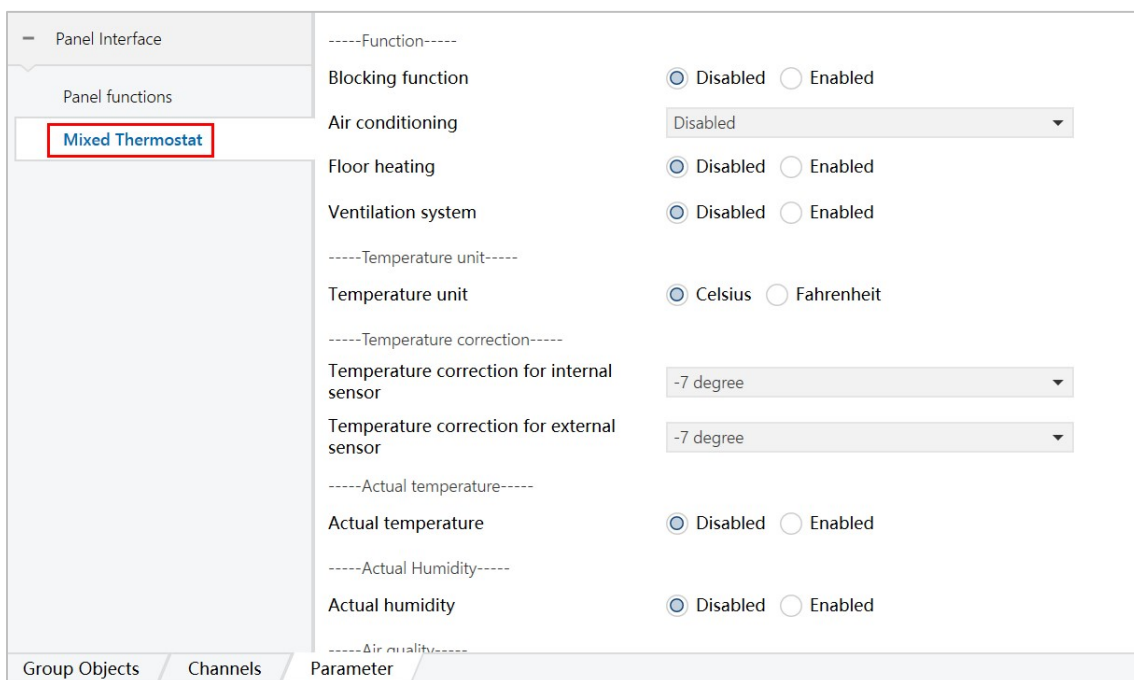

Figure 6.2.0

Parameter	Description
Blocking function	Indicates a blocking function. The options are: Enabled and Disabled.
Defined value for blocking	Indicates the definition value of blocking. This parameter is visible when "Enabled" is selected in "Blocking function". The options are: blocking = 1, unblocking =0, blocking = 0, unblocking =1.
Blocking value after voltage recovery	Indicates the blocking value after voltage recovery. This parameter is visible when "Blocking function" is selected as "Enabled". The options are: unblocking, blocking, and as before voltage failure.
Air conditioning	Indicates the selection of air conditioning. Available options: Disabled, Air conditioning, HVAC. For details, see 6.2.1 and 6.2.2.
Floor heating	Indicates floor heating, the options are: Enabled, Disabled, see 6.2.3 for details.
Ventilation system	Indicates the fresh air system. The options are: Enabled, Disabled. For details, see 6.2.4.
Temperature unit	The unit for expressing temperature. Available options: Celsius, Fahrenheit.
Temperature correction for internal sensor	Indicates the temperature value corrected from the internal temperature sensor. Options: -7 degree ~ 7 degree.
Temperature correction for external sensor	Indicates the temperature value corrected from the external temperature sensor. Options: -7 degree ~ 7 degree.
Actual temperature	Indicates the actual temperature, options: Enabled, Disabled
Source for actual temperature	Indicates the source of actual temperature. This parameter is visible when "Actual humidity" is selected as Enabled. The options are: internal value and external knx bus.
Send actual temperature	Indicates sending actual temperature. This parameter is visible when "internal value" is selected in "Source for actual temperature". The options are: Enabled and Disabled.

The mode for sending value	Indicates the operation of sending a value. This parameter is visible when "Enabled" is selected for "Send actual temperature" or "Send actual humidity". The options are: transmit value in cycle, transmit value in the event of changes;
The time in cycles	Indicates the cycle period. This parameter is visible when "transmit value in cycle" is selected in "The mode for sending value". The options are: 1second, 2seconds...120minutes.
Actual humidity	Indicates the actual humidity. Available options: Enabled, Disabled.
Source for actual humidity	Indicates the source of the actual temperature. This parameter is visible when "Actual humidity" is selected as Enabled. The options are: internal value (internal detection of the temperature control panel) and external knx bus (issued by the KNX bus).
Send actual humidity	Indicates sending actual temperature. This parameter is visible when "internal value" is selected in "Source for actual humidity". The options are: Enabled and Disabled.
Air Quality page	Indicates the Air Quality page, options are: Enabled, Disabled.
Display actual temperature	Displays the actual temperature. This parameter is visible when "Enabled" is selected in "Air Quality page". The options are: Enabled, Disabled.
Display actual humidity	Displays the actual humidity. This parameter is visible when "Enabled" is selected in "Air Quality page". The options are: Enabled, Disabled.
Display actual PM2.5	Displays actual PM2.5. This parameter is visible when "Enabled" is selected in "Air Quality page". The options are: Enabled, Disabled.
Display actual PM10	Displays actual PM10. This parameter is visible when "Enabled" is selected in "Air Quality page". The options are: Enabled, Disabled.
Display actual HCHO	Displays the actual HCHO. This parameter is visible when "Enabled" is selected in the "Air Quality page". The options are: Enabled, Disabled.

Display actual TVOC	Displays actual TVOC. This parameter is visible when "Enabled" is selected in "Air Quality page".  The options are: Enabled, Disabled.
Display actual CO2	Displays actual CO2. This parameter is visible when "Enabled" is selected in "Air Quality page".  The options are: Enabled, Disabled.
Display actual AQI	Displays the actual AQI. This parameter is visible when "Enabled" is selected in the "Air Quality page". The options are: Enabled, Disabled.
Thermostat backlight	Indicates the backlight of the thermostat. Options: Enabled, Disabled. For details, see 6.2.5.

## 6.2.1 Air conditioning

When the parameter "Air conditioning" is selected as "Air conditioning", it is shown as Figure 6.2.1.

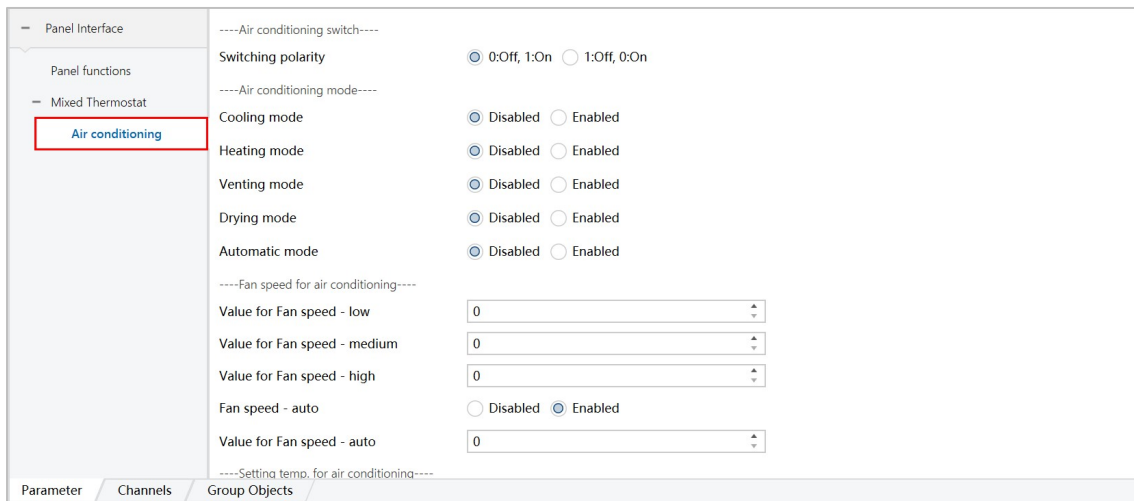

Figure 6.2.1

Parameter	description
Switching polarity	Indicates the switch polarity, options: 0:Off, 1:On, 1:Off, 0:On.
Cooling mode	Indicates cooling mode, options: Disabled, Enabled;
	When Enabled is selected, there is a parameter "Cooling value" indicating the value sent in cooling mode, with options: 0~255;

Heating mode	Indicates heating mode, options: Disabled, Enabled;
	When Enabled is selected, there is a parameter "Heating mode" indicating the value sent by the heating mode, with options: 0~255;
Venting mode	Indicates ventilation mode, options: Disabled, Enabled;
	When Enabled is selected, there is a parameter "Venting mode" indicating the value sent by the ventilation mode, with options: 0~255;
Drying mode	Indicates dehumidification mode, options: Disabled, Enabled;
	When Enabled is selected, there is a parameter "Drying mode" which indicates the value sent in the dehumidification mode, with options: 0~255;
Automatic mode	Indicates automatic mode, options: Disabled, Enabled;
	Indicates automatic mode, options: Disabled, Enabled; when Enabled is selected, there is a parameter "Automatic mode" indicating the value sent in automatic mode, options: 0~255;
Value for Fan speed - low	Indicates low wind speed value, options: 0, 1, 2, 3...255;
Value for Fan speed- medium	Indicates the wind speed value, options: 0, 1, 2, 3...255;
Value for Fan speed - high	Indicates the high wind speed value, options: 0, 1, 2, 3...255;
Fan speed - auto	Indicates automatic wind speed, options: Enabled, Disabled;
	When "Enabled" is selected, there is a parameter "Value for Fan speed auto" indicating the value of automatic fan speed, with options: 0, 1, 2, 3...255;
The change in each step for setting temperature	Indicates the change of each step of temperature setting, options: 0.1°C, 0.5°C, 1°C, 1.5°C, 2°C;
Min. set temperature	Indicates setting the minimum temperature, options: 0, 1, 2...45°C

[0..45°C]	
Max. set temperature [0..45°C]	Indicates setting the maximum temperature, options: 0, 1, 2...45°C
Temperature source	Indicates the temperature source. Available options: 'Internal sensor', 'External sensor'.
	When "External sensor" is selected, there are parameters: ① "Time period for request external sensor (min)" indicates the time (minutes) for requesting external sensor, options: 0, 1, 2, 3...255; ② "Read external sensor after voltage recovery" indicates reading external sensor after voltage recovery, options: No, Yes.

## 6.2.2 HVAC

When the parameter "Air conditioning" is selected as "HVAC", it is shown as Figure 6.2.2.

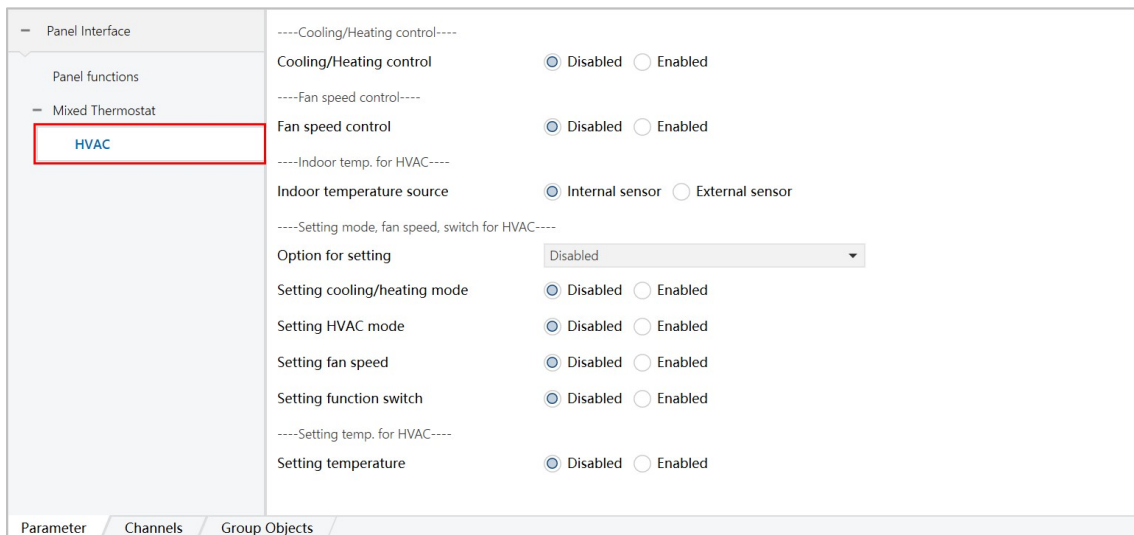

Figure 6.2.2

1. The parameter "Cooling/Heating control" indicates cooling/heating control, and the options are: Enabled, Disabled;
2. The parameter "Type of HVAC control" indicates the type of HVAC control. This parameter is visible when "Enabled" is selected for "Cooling/Heating control", and the options are: Cooling, Heating, Heating and Cooling;

(1) When "Cooling" is selected, there is a parameter "Method of cooling control" indicating the cooling control method. The

options are: Switching on/off (use 2-point control), Switching PWM (use PI control), Continuous control (use PI control);

①When "Switching on/off (use 2-point control)" is selected, there are parameters:

Parameter	Description
Hysteresis *0.1C(For cooling)	Indicates hysteresis*0.1°C (for cooling), options: 0~255;
Object type of cooling control	Indicates the type of cooling control object, options: 1bit, 1byte;

②When "Switching PWM (use PI control)" is selected, there are parameters:

Parameter	Description
PWM cycle time[1...255]*1min	Indicates PWM cycle time (minutes), options: 1~255;
Cooling speed	Indicates cooling speed. Options: Cooling ceiling (5K/150min) (Cooling maximum limited5K/150min), Split unit (4K/90min), Fan convector (4K/90min), User define.
	When "User define" is selected, there is a parameter "Proportional range for cooling" which means setting the cooling proportion range. The options are: 0~255;
	When "User define" is selected, there is a parameter "Readjust time for cooling" which means readjust the cooling time. The options are: 0~255;

③When "Continuous control (use PI control)" is selected, there are parameters

Parameter	Description
Cooling speed	Indicates cooling speed. Options: Cooling ceiling (5K/150min) (cooling maximum limited 5K/150min), Split unit (4K/90min), Fan convector (4K/90min), User define.
	When "User define" is selected, there is a parameter "Proportional range for cooling"

	which means setting the cooling proportion range. The options are: 0~255;
	When "User define" is selected, there is a parameter "Readjust time for cooling" which means readjust the cooling time.
Send control value on change by [0..255]	Indicates sending control value [0..255] when sending changes, options: 0~255;

(2) When "Heating" is selected, there is a parameter "Method of heating control" indicating the heating control method. The options are: Switching on/off (use 2-point control), Switching PWM (use PI control), Continuous control (use PI control);

①When "Switching on/off (use 2-point control)" is selected, there are parameters:

Parameter	Description
Hysteresis *0.1°C(For heating)	Indicates the hysteresis temperature of heating*0.1°C, options: 0~255;
Object type of heating control	Indicates the type of heating control object, options: 1bit, 1byte;

②When "Switching PWM (use PI control)" is selected, there are parameters

Parameter	Description
PWM cycle time[1...255]*1min	Indicates PWM cycle time (minutes), options: 1~255;
Heating speed	Indicates the heating speed. Options: Hot water heating (5K/150 min), Floor heating (5K/240 min), Electric heating (4K/100 min), Split unit (4K/90min), User define.
	When "User define" is selected, there is a parameter "Proportional range for cooling" which means setting the heating proportional range. The options are: 0~255;
	When "User define" is selected, there is a parameter "Readjust time for Heating" which means to readjust the heating time. The options are: 0~255;

Object type of heating control	Indicates the type of heating control object, options: 1bit, 1byte;
--------------------------------	---

③When "Continuous control (use PI control)" is selected, there are parameters

Parameter	Description
Heating speed	Indicates the heating speed. Options: Hot water heating (5K/150 min), Floor heating (5K/240 min), Electric heating (4K/100 min), Split unit (4K/90min), User define.
	When "User define" is selected, there is a parameter "Proportional range for cooling" which means setting the heating proportional range. The options are: 0~255;
	When "User define" is selected, there is a parameter "Readjust time for Heating" which means to readjust the heating time. The options are: 0~255;
Send control value on change by  [0..255]	Indicates sending control value [0..255] when sending changes, options: 0~255;

(3) When "Heating and cooling" is selected, there is a parameter "Control system" to indicate the control system settings.

The options are: 2 pipes system (2 control system), 4 pipes system (4 control system);

(A) When the option is "2 pipes system", there is a parameter "Method of cooling/heating control" to indicate the cooling/heating control method. The options are: Switching on/off (use 2-point control), Switching PWM (use PI control),

Continuous control (use PI control);

①When "Switching on/off (use 2-point control)" is selected, there are parameters:

Parameter	Description
Hysteresis *0.1°C(For cooling)	Indicates the hysteresis temperature of cooling*0.1°C, options: 0~255;
Hysteresis *0.1°C(For heating)	Indicates the hysteresis temperature of heating*0.1°C, options: 0~255;

Object type of cooling control	Indicates the type of heating control object, options: 1bit, 1byte;
--------------------------------	---

②When "Switching PWM (use PI control)" is selected, there are parameters

Parameter	Description
PWM cycle time[1...255]*1min	Indicates PWM cycle time (minutes), options: 1~255;
Cooling speed	Indicates cooling speed. Options: Cooling ceiling (5K/150min) (Cooling maximum limited 5K/150min), Split unit (4K/90min), Fan convector (4K/90min), User define.
	When "User define" is selected, there is a parameter "Proportional range for cooling" which means setting the cooling proportion range. The options are: 0~255;
	When "User define" is selected, there is a parameter "Readjust time for cooling" which means readjust the cooling time.
Heating speed	Indicates the heating speed. Options: Hot water heating (5K/150 min), Floor heating (5K/240 min), Electric heating (4K/100 min), Split unit (4K/90min), User define.
	When "User define" is selected, there is a parameter "Proportional range for Heating" which means setting the heating proportional range. The options are: 0~255;
	When "User define" is selected, there is a parameter "Readjust time for cooling" which means to readjust the heating time. The options are: 0~255;
Object type of heating control	Indicates the type of heating control object, options: 1bit, 1byte;

③When "Continuous control (use PI control)" is selected, there are parameters

Parameter	Description
Cooling speed	Indicates cooling speed. Options: Cooling ceiling (5K/150min) (cooling maximum

	<p>limited 5K/150min), Split unit (4K/90min), Fan convector (4K/90min), User define.</p> <p>When "User define" is selected, there is a parameter "Proportional range for cooling" which means setting the cooling proportion range. The options are: 0~255;</p> <p>When "User define" is selected, there is a parameter "Readjust time for cooling" which means readjust the cooling time.</p>
<p>Send control value on change by</p> <p>[0..255]</p>	<p>Indicates that the control value [0..255] is sent when the cooling speed is changed. The options are: 0~255;</p>
<p>Heating speed</p>	<p>Indicates the heating speed. Options: Hot water heating (5K/150 min), Floor heating (5K/240 min), Electric heating (4K/100 min), Split unit (4K/90min), User define.</p> <p>When "User define" is selected, there is a parameter "Proportional range for cooling" which means setting the heating proportional range. The options are: 0~255;</p> <p>When "User define" is selected, there is a parameter "Readjust time for cooling" which means to readjust the heating time. The options are: 0~255;</p>
<p>Send control value on change by</p> <p>[0..255]</p>	<p>Indicates that the control value [0..255] is sent when the heating speed is changed, options: 0~255;</p>

(B) When the option is "4 pipes system", there is a parameter "Method of cooling control" to indicate the cooling control method. The options are: Switching on/off (use 2-point control), Switching PWM (use PI control), Continuous control (use PI control);

①When "Switching on/off (use 2-point control)" is selected, there are parameters:

Parameter	Description
Hysteresis *0.1C(For cooling)	Indicates hysteresis*0.1°C (for cooling), options: 0~255;

Object type of cooling control	Indicates the type of cooling control object, options: 1bit, 1byte;
--------------------------------	---

②When "Switching PWM (use PI control)" is selected, there are parameters

Parameter	Description
PWM cycle time[1...255]*1min	Indicates PWM cycle time (minutes), options: 1~255;
Cooling speed	Indicates cooling speed. Options: Cooling ceiling (5K/150min) (Cooling maximum limited 5K/150min), Split unit (4K/90min), Fan convector (4K/90min), User define.
	When "User define" is selected, there is a parameter "Proportional range for cooling" which means setting the cooling proportion range. The options are: 0~255;
	When "User define" is selected, there is a parameter "Readjust time for cooling" which means readjust the cooling time. The options are: 0~255;
Object type of cooling control	Indicates the type of cooling control object, options: 1bit, 1byte;

③When "Continuous control (use PI control)" is selected, there are parameters

Parameter	Description
Cooling speed	Indicates cooling speed. Options: Cooling ceiling (5K/150min) (cooling maximum limited 5K/150min), Split unit (4K/90min), Fan convector (4K/90min), User define.
	When "User define" is selected, there is a parameter "Proportional range for cooling" which means setting the cooling proportion range. The options are: 0~255;
	When "User define" is selected, there is a parameter "Readjust time for cooling" which means readjust the cooling time.
Send control value on change by	Indicates sending control value [0..255] when sending changes, options: 0~255;

[0..255]	
----------	--

④ There is a parameter "Method of heating control" to indicate the method of heating control. The options are: Switching on/off (use 2-point control), Switching PWM (use PI control), Continuous control (use PI control);

① When "Switching on/off (use 2-point control)" is selected, there are parameters

Parameter	Description
Hysteresis*0.1°C(For heating)	Indicates the hysteresis temperature of heating*0.1°C, options: 0~255;
Object type of heating control	Indicates the type of heating control object, options: 1bit, 1byte;

② When "Switching PWM (use PI control)" is selected, there are parameters

Parameter	Description
PWM cycle time[1...255]*1min	Indicates PWM cycle time (minutes), options: 1~255;
Heating speed	Indicates the heating speed. Options: Hot water heating (5K/150 min), Floor heating (5K/240 min), Electric heating (4K/100 min), Split unit (4K/90min), User define.
	When "User define" is selected, there is a parameter "Proportional range for cooling" which means setting the heating proportional range. The options are: 0~255;
	When "User define" is selected, there is a parameter "Readjust time for Heating" which means to readjust the heating time. The options are: 0~255;
Object type of heating control	Indicates the type of heating control object, options: 1bit, 1byte;

③ When "Continuous control (use PI control)" is selected, there are parameters

Parameter	Description
Heating speed	Indicates the heating speed. Options: Hot water heating (5K/150 min), Floor heating (5K/240 min), Electric heating (4K/100 min), Split unit (4K/90min), User define.
	When "User define" is selected, there is a parameter "Proportional range for cooling" which means setting the heating proportional range. The options are: 0~255;
	When "User define" is selected, there is a parameter "Readjust time for Heating" which means to readjust the heating time. The options are: 0~255;
Send control value on change by [0..255]	Indicates sending control value [0..255] when sending changes, options: 0~255;

3. The parameter "Fan speed control" indicates the fan speed control. The options are: Disabled, Enabled. When "Enabled" is selected, the following options are available:

Parameter	Description
Data type for fan speed control	Indicates the data type for controlling the fan speed. Options: 1bit, 1byte,
	When the "1bit" value is selected, there is a parameter "Delay between fan speed switch [0..255] * 0.1s" indicating the interval time (0.1s) of the fan speed switching. The options are: 0, 1, 2, 3...255;
	When the "1byte" value is selected, there is a parameter "Value for Fan speed off" which indicates the value of controlling "fan off". The options are: 0~255;
	When the "1byte" value is selected, there is a parameter "Value for Fan speed low" to control the "low wind speed" value, with options: 0~255;
	When the "1byte" value is selected, there is a parameter "Value for Fan speed medium" to

	<p>control the "medium fan speed" value, with options: 0~255;</p>
	<p>When the "1byte" value is selected, there is a parameter "Value for Fan speed high" to indicate the value of controlling the "high wind speed", with options: 0~255;</p>
	<p>There is a parameter "Association heating and cooling states" which indicates that the fan is associated with the cooling and heating state, for example, the fan is started only when cooling or heating. The options are: Disabled, Enabled.</p>
<p>--In auto mode (Cooling)--</p>	<p>Indicates the automatic mode of setting the cooling state.</p>
	<p>Fan 1--&gt;Fan 2 [°C] (Difference value between set temp and actual temp) means that in automatic mode, the fan speed level 1 switches to the fan speed level 2 according to the "difference between the set temperature and the actual temperature". The difference is set here. The options are: 0, 1, 2, 3...15; (For example: if the option is "2", when the "difference between the set temperature and the actual temperature" is greater than or equal to 2, the fan speed 1 automatically switches to the fan speed 2)</p>
	<p>Fan 2--&gt;Fan 3[°C] (Difference value between set temp and actual temp) means that in automatic mode, the fan speed level 2 switches to the fan speed level 3 according to the "difference between the set temperature and the actual temperature". The difference is set here. The options are: 0, 1, 2, 3...15; (For example: if the option is "2", when the "difference between the set temperature and the actual temperature" is greater than or equal to 2, the fan speed 2 automatically switches to the fan speed 3)</p>
<p>--In auto mode (Heating)--</p>	<p>Indicates the automatic mode of setting the heating status</p>
	<p>Fan 1--&gt;Fan 2 [°C] (Difference value between set temp and actual temp) means that in automatic mode, the fan speed level 1 switches to the fan speed level 2 according to the</p>

	<p>"difference between the set temperature and the actual temperature". The difference is set here. The options are: 0, 1, 2, 3...15; (For example: if the option is "2", when the "difference between the set temperature and the actual temperature" is greater than or equal to 2, the fan speed 1 automatically switches to the fan speed 2)</p>
	<p>Fan 2--&gt;Fan 3[°C] (Difference value between set temp and actual temp) means that in automatic mode, the fan speed level 2 switches to the fan speed level 3 according to the "difference between the set temperature and the actual temperature". The difference is set here. The options are: 0, 1, 2, 3...15; (For example: if the option is "2", when the "difference between the set temperature and the actual temperature" is greater than or equal to 2, the fan speed 2 automatically switches to the fan speed 3)</p>

4. The parameter "Indoor temperature source" indicates the indoor temperature source. The options are: "Internal sensor" indicates the internal temperature; "External sensor" indicates the external temperature. When "External sensor" is selected, there are:

Parameter	Description
Time period for request external sensor(min)	Indicates the time (minutes) to request the external sensor. Options: 0, 1, 2, 3...255;
Read external sensor after voltage recovery	Indicates reading external sensors after voltage is restored. Options: No, Yes

5. The parameter "Option for setting" indicates the setting options of HVAC. The options are: "Disabled", "Read setting object at voltage recovery", "Send setting as feedback when receiving setting".

6. The parameter "Setting cooling/heating mode" means setting the cooling/heating mode. The options are: Disabled, Enabled.

When "Enabled" is selected, there are:

Parameter	Description
Data type for setting cooling/heating mode	Indicates the data type for setting the cooling/heating mode. Options: 1bit, 1byte
	When the "1byte" value is selected, there is a parameter "Value for cooling mode" indicating the value of the cooling mode. The options are: 0, 1, 2, 3...255;
	When the "1byte" value is selected, there is a parameter "Value for heating mode" which indicates the value of the heating mode.
Cooling/heating mode after the voltage recovery	Indicates the cooling/heating mode selected after the voltage is restored. Options: Cooling (cooling), Heating (heating), As before voltage failure (same as before power failure);

7. The parameter "Setting HVAC mode" means setting the HVAC mode. The options are: Disabled, Enabled. When "Enabled"

is selected, there are:

Parameter	Description
---Set point method for HVAC mode---	A set point method that indicates the HVAC mode;
---Cooling---	Indicates the temperature values of each mode of cooling state in HVAC mode, and custom settings;
	Set point Temp. in comfort mode [°C] indicates the set temperature point of comfort mode [°C], options: 5, 6, 7, 8...255;
	Set point Temp. in standby mode[°C] indicates the temperature point of the set standby

	mode[°C], options: 5, 6, 7, 8...255;
	Set point Temp. in economy mode[°C] indicates the temperature point of the energy-saving mode[°C], options: 5, 6, 7, 8...255;
	Set point Temp. in heat protection mode [°C] indicates the temperature point of overheat protection mode [°C], options: 5, 6, 7, 8...255;
---Heating---	Set point Temp. in comfort mode [°C] indicates the set temperature point of comfort mode [°C], options: 5, 6, 7, 8...255;
	Set point Temp. in standby mode[°C] indicates the temperature point of the set standby mode[°C], options: 5, 6, 7, 8...255;
	Set point Temp. in economy mode[°C] indicates the temperature point of the energy-saving mode[°C], options: 5, 6, 7, 8...255;
	Set point Temp. in heat protection mode [°C] indicates the temperature point in the antifreeze protection mode [°C], options: 5, 6, 7, 8...255;
HVAC mode after voltage recovery	Indicates the HVAC mode after power failure recovery. Options: Comfort mode, Standby mode, Economy mode, Protection mode, As before voltage failure

8. The parameter "Setting fan speed" means setting the HVAC fan speed. The options are: Disabled, Enabled. When

"Enabled" is selected, there are:

Parameter	Description
Value for setting fan speed off	Indicates the value for setting the wind speed to be turned off. Options: 0, 1, 2, 3...255 ;
Value for setting fan speed low	Indicates the value of setting low wind speed, options: 0, 1, 2, 3...255;

Value for setting fan speed  medium	Indicates the wind speed value in the setting, options: 0, 1, 2, 3...255;
Value for setting fan speed  high	Indicates the value of setting the high wind speed, options: 0, 1, 2, 3...255;
Value for setting fan speed  auto	Indicates the value of setting the automatic wind speed, options: 0, 1, 2, 3...255;
Setting fan speed after the  voltage recovery	Indicates setting the wind speed after power failure recovery. Options include: Fan speed - off, speed low, speed medium, speed high, As before voltage failure;

9. The parameter "Setting function switch" indicates setting the switch function. The options are: Disabled, Enabled. When "Enabled" is selected, there is a parameter "Function switch after the voltage recovery" for the switch function after power failure recovery. The options are: Off, On, As before voltage failure.

10. The parameter "Setting temperature" means setting the temperature of HVAC. The options are: Disabled, Enabled. When "Enabled" is selected, the following options are available:

Parameter	Description
The change in each step for  setting temperature	Indicates each step change of the set temperature, options: 0.1°C, 0.5°C...2°C;
Min. set temperature[0...45°C]	Indicates setting the minimum temperature, options: 0°C, 1°C...45°C;
Max. set temperature[0...45°C]	Indicates setting the maximum temperature, options: 0°C, 1°C...45°C;
Setting temperature after the  voltage recovery	Indicates the temperature after power failure recovery. Options include: Defined temperature, As before voltage failure;

	When "Defined temperature" is selected, there is a parameter "The value for Defined temperature" indicating the value of defined temperature. The options are: 0°C, 1°C...45°C;
--	---

### 6.2.3 Floor heating

When the parameter "Floor heating" is selected as "Enabled", as shown in Figure 6.2.3.

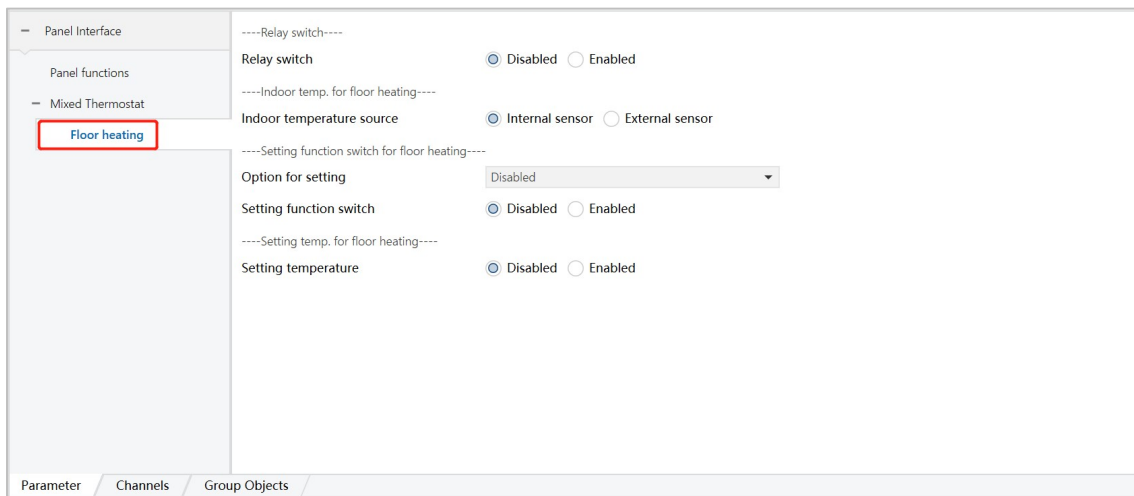

Figure 6.2.3

Parameter	Description
Relay switch	Indicates relay switch, options: Disabled, Enabled
	When "Enabled" is selected, there is a parameter "Temperature Hysteresis[0...255]*0.1" to indicate the temperature hysteresis value, and the options are: 0, 1, 2, 3...255; (When the actual temperature (T) > the set temperature + hysteresis value, stop heating; when the actual temperature (T) < the set temperature - hysteresis value, start heating.)
Indoor temperature source	Indicates the indoor temperature source, options: Internal sensor, External sensor
	When "External sensor" is selected, there is a parameter "Time period for request external sensor (min)" which indicates the time period (minutes) for requesting the external sensor. The options are: 0, 1, 2, 3...255;

	<p>When "External sensor" is selected, there is a parameter "Read external sensor after voltage recovery" to indicate whether to read the external sensor after power failure recovery. The options are: No, Yes.</p>
Setting function switch	<p>Indicates setting the switch function, options: Disabled, Enabled.</p>
	<p>When "Enabled" is selected, there is a parameter "Function switch after the voltage recovery" to indicate the switch function after power failure recovery. The options are: Off, On, As before voltage failure.</p>
Setting temperature	<p>Indicates setting temperature, options: Disabled, Enabled</p>
	<p>When "Enabled" is selected, there is a parameter "The change in each step for setting temperature" to indicate each step change of the setting temperature. The options are: 0.1°C, 0.5°C...2°C;</p>
	<p>When "Enabled" is selected, there is a parameter "Min. set temperature [0...45°C]" to set the minimum temperature, options: 0°C, 1°C...45°C;</p>
	<p>When "Enabled" is selected, there is a parameter "Max. set temperature [0...45°C]" to set the maximum temperature, options: 0°C, 1°C...45°C;</p>
	<p>When "Enabled" is selected, there is a parameter "Setting temperature after the voltage recovery" indicating the temperature after power failure recovery, and the options are: Defined temperature, As before voltage failure; When "Defined temperature" is selected, there is a parameter "The value for Defined temperature" indicating the value of the defined temperature, and the options are: 0°C, 1°C...45°C;</p>

When you choose "Enabled" in "Ventilation system", would be show as Figure 6.2.4

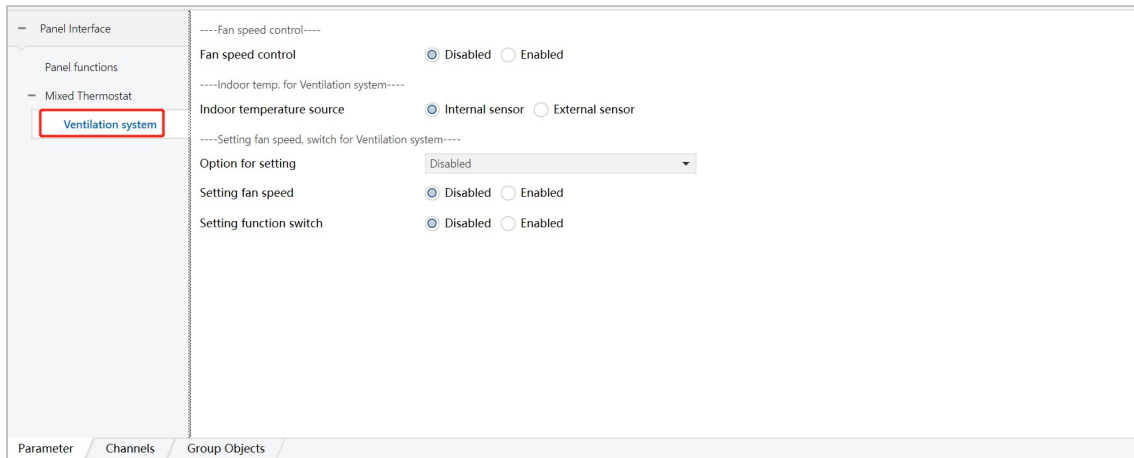

Figure 6.2.4

1. The parameter "Fan speed control" indicates the fan speed control. The options are: Disabled, Enabled. When "Enabled" is selected, the following options are available:

Parameter	Description
Data type for fan speed control	Indicates the data type for controlling the fan speed. Options: 1bit, 1byte,
	When the "1bit" value is selected, there is a parameter "Delay between fan speed switch [0.. 255] * 0.1s" indicating the interval time (0.1s) of the fan speed switching. The options are: 0, 1, 2, 3...255;
	When the "1byte" value is selected, there is a parameter "Value for Fan speed off" which indicates the value of controlling "fan off". The options are: 0~255;
	When the "1byte" value is selected, there is a parameter "Value for Fan speed low" to control the "low wind speed" value, with options: 0~255;
	When the "1byte" value is selected, there is a parameter "Value for Fan speed medium" to control the "medium fan speed" value, with options: 0~255;
	When the "1byte" value is selected, there is a parameter "Value for Fan speed high" to

	indicate the value of controlling the "high wind speed", with options: 0~255;
--	---

2. The parameter "Indoor temperature source" indicates the indoor temperature source. The options are: Internal sensor (internal sensor), External sensor (external sensor). When "External sensor" is selected,

Parameter	Description
Time period for request external sensor (min)	Indicates the time period (minutes) for requesting external sensors. Options: 0, 1, 2, 3...255;
Read external sensor after voltage recovery	Indicates whether to read external sensors after power failure recovery, options: No, Yes;

3. The parameter "Option for setting" indicates the setting option for floor heating. The options are: "Disabled", "Read setting object at voltage recovery", and "Send setting as feedback when receiving setting".

4. The parameter "Setting fan speed" means setting the floor heating fan speed. The options are: Disabled, Enabled. When "Enabled" is selected, there are:

Parameter	Description
Value for setting fan speed off	Indicates the value for setting the wind speed to be turned off. The options are: 0, 1, 2, 3...255;
Value for setting fan speed low	Indicates the value of setting low wind speed, options: 0, 1, 2, 3...255;
Value for setting fan speed medium	Indicates the wind speed value in the setting, options: 0, 1, 2, 3...255;
Value for setting fan speed	Indicates the value of setting the high wind speed, options: 0, 1, 2, 3...255;

high	
Value for setting fan speed	Indicates the value of setting the automatic wind speed, options: 0, 1, 2, 3...255;
auto	
Setting fan speed after the voltage recovery	Indicates setting the fan speed after power failure recovery. Options include: Fan speed - off, speed low, speed medium, speed high, and As before voltage failure.

4. The parameter "Setting function switch" means setting the switch function. The options are: Disabled, Enabled. When "Enabled" is selected, there is a parameter "Function switch after the voltage recovery" for the switch function after power failure recovery. The options are: Off, On, As before voltage failure.

## 6.2.5 Thermostat backlight

When the parameter "Thermostat backlight" is selected as "Enabled", it is shown in Figure 6.2.5.

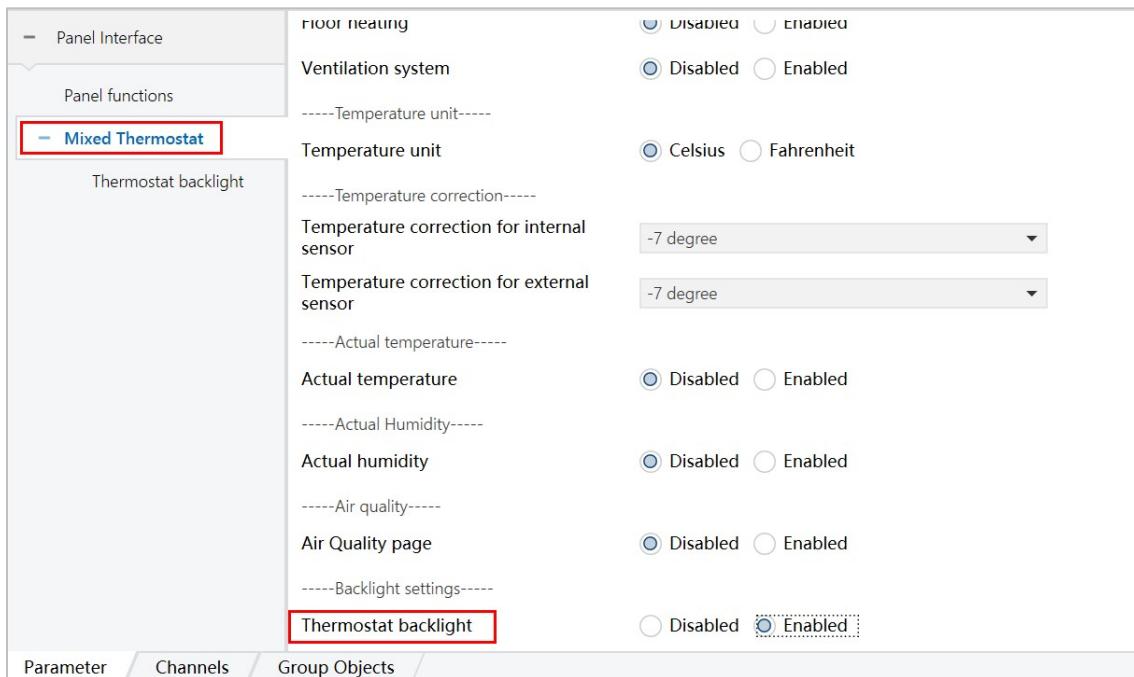

Figure 6.2.5

The parameter Thermostat backlight mode indicates the thermostat backlight mode. This parameter is visible when

"Thermostat backlight" is selected as "Enabled". The options are: Always, Delay mode, According to button's backlight mode

1) When "Always" is selected, the following parameters appear, as shown in Figure 6.2.6.

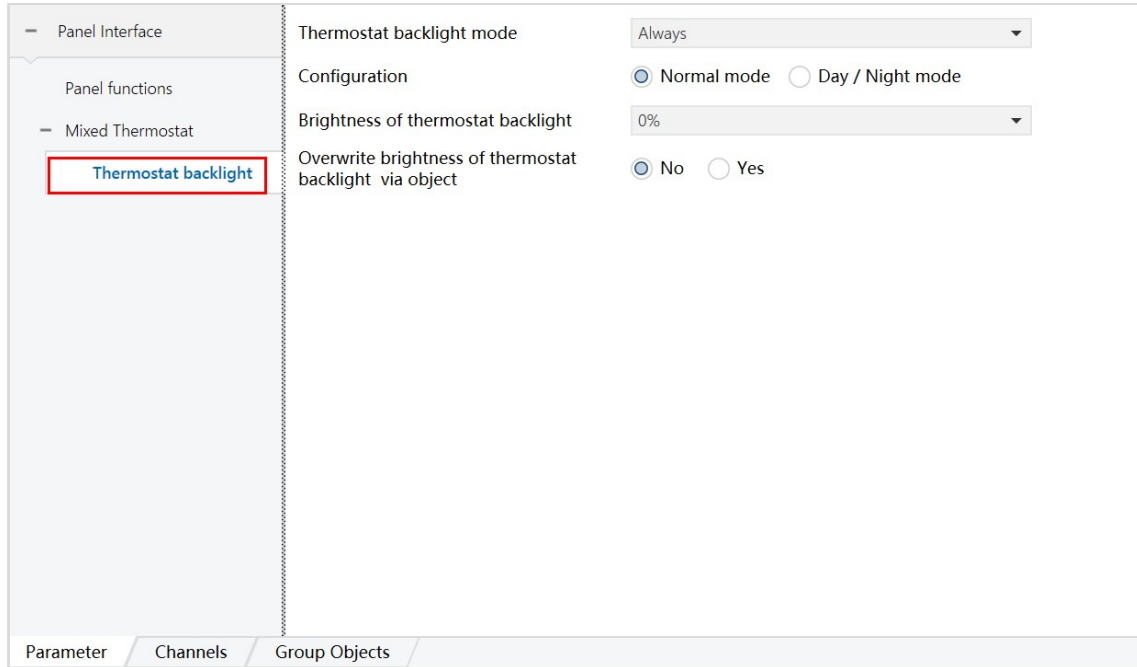

Figure 6.2.6

Parameter	Description
Configuration	Indicates configuration. This parameter is visible when "Always" is selected in "Thermostat backlight mode". The options are: Normal mode, Day / Night mode.
Polarity of Day/Night mode	Indicates the polarity of the day/night mode. This parameter is visible when "Always" is selected in "Thermostat backlight mode" and "Day / Night mode" is selected in "Configuration". The options are: Day=1, Night=0, Day=0, Night=1.
Read Day/Night mode at voltage recovery	Indicates the function of reading the day/night mode when the voltage is restored. This parameter is visible when "Always" is selected in "Thermostat backlight mode" and "Day / Night mode" is selected in "Configuration". The options are: No, Yes.
Brightness of thermostat backlight	Indicates the backlight brightness of the thermostat. This parameter is visible when "Always" is selected in "Thermostat backlight mode". The options are: 0%, 1%, 2%...100%.

<p>Over write brightness of thermostat backlight via object</p>	<p>Indicates that the backlight brightness of the thermostat is overwritten by the object. This parameter is visible when "Always" is selected in "Thermostat backlight mode". The options are:</p> <p>No, Yes.</p>
---	---

2) When "Delay mode" is selected, the following parameters appear, as shown in Figure 6.2.7

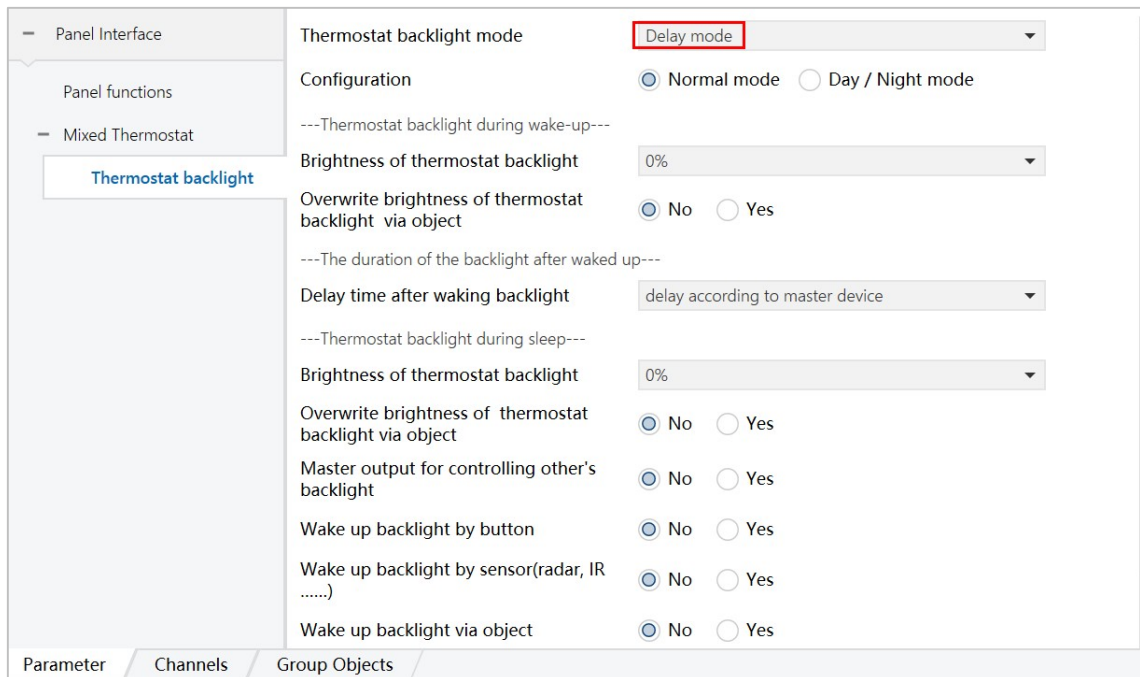

Figure 6.2.7

Parameter	Description
Configuration	Indicates configuration, options: Normal mode, Day / Night mode.
Polarity of Day/Night mode	Indicates the polarity of the day/night mode. This parameter is visible when "Day / Night mode" is selected in "Configuration". The options are: Day=1, Night=0, Day=0, Night=1.
Read Day/Night mode at voltage recovery	Indicates the function of reading the day/night mode when the voltage is restored. This parameter is visible when "Day / Night mode" is selected in "Configuration". The options are: No, Yes.
Brightness of thermostat	Indicates the backlight brightness of the thermostat. Available options: 0%, 1%, 2%...100%.

backlight	
Over write brightness of thermostat backlight via object	Indicates whether to override the backlight brightness of the thermostat through an object. The options are: No, Yes.
Delay time after waking backlight	The delay time for the backlight to turn off after being awakened. Options: delay according to master device, delay according to radar or IR, 1second, 2seconds...120minutes.
Master output for controlling other's backlight	As the master device, it sends switch information to control the backlight of other slave panel devices. The options are: Yes and No.
Wake up backlight by button	Use the button to wake up the backlight, options: Yes, No.
Wake up backlight by sensor(radar ,IR..... )	Wake up the backlight through sensor (radar, infrared) options: Yes, No.
Wake up backlight via object	Wake up the backlight through an object. Available options: Yes, No.
Output triggering signal for waking backlight	Use output trigger signal to wake up the backlight, options: Yes, No.

3) When "According to button's backlight mode" is selected, as shown in Figure 6.2.8

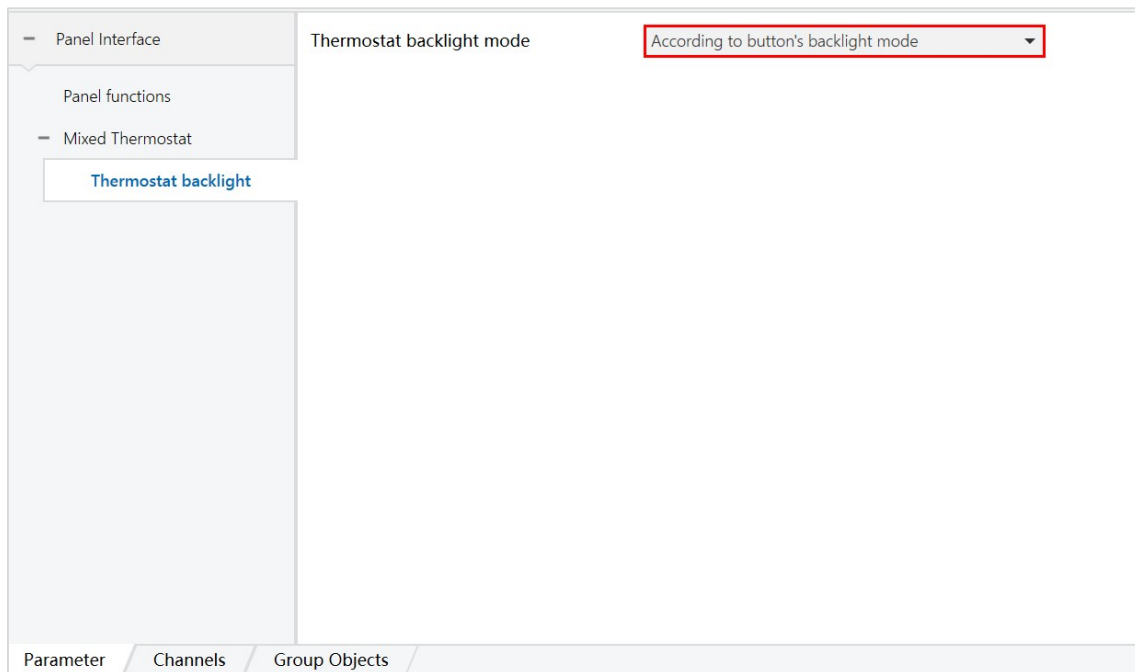

Figure 6.2.8

When this parameter is selected, the backlight mode of the thermostat is executed according to the backlight mode of the buttons.

### 6.3 Parameter setting interface Mixed Actuator — **Not available**

### 6.4 Parameter setting interface Scene Module

“Scene Module” represents the scene module function setting interface. There are 8 scene modules available for setting. They are enabled when “Enabled” is selected, as shown in Figure 6.4.1.

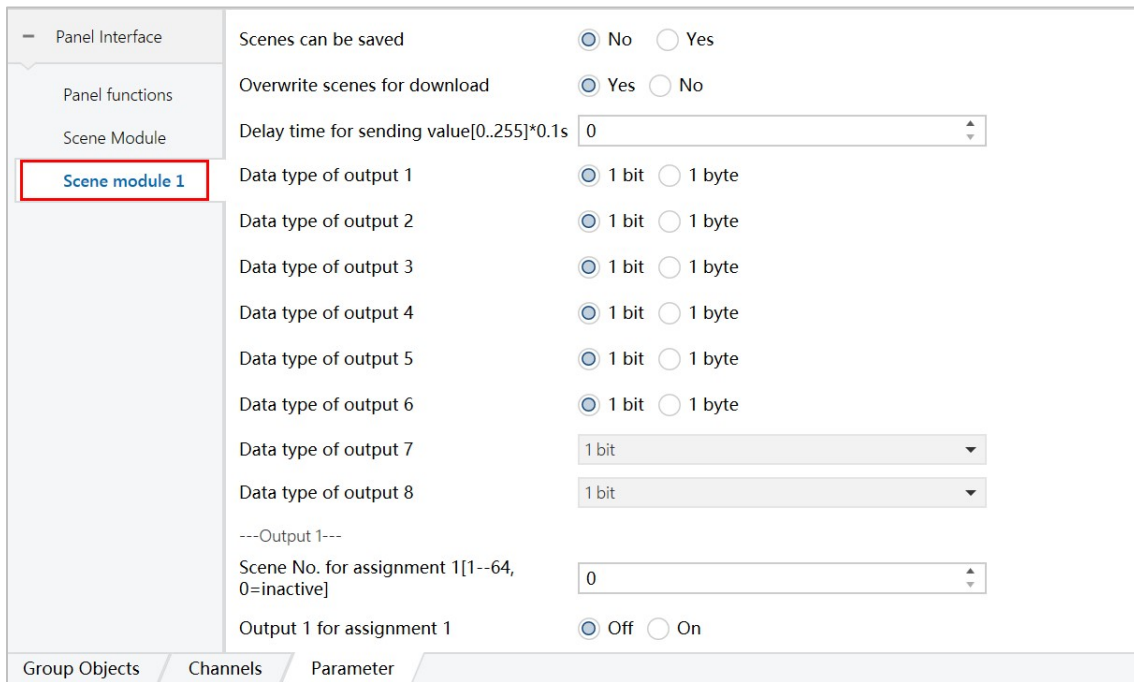

Figure 6.4.1

Parameter	Description
Scene module X	Indicates scene module X (X=1~8), a total of 8 scene modules are available;
Scenes can be saved	Indicates the scene saving function, options: NO (disable), Yes (enable); (When "Yes" is selected, the scene learned through the scene learning function is saved);
Overwrite scenes for download	Indicates that when downloading data, the scenario configured in the data covers the scenario learned through the scenario learning function. The options are: Yes, NO;
Delay time for sending value[0..255]*0.1s	Indicates the delay time of sending value [0..255]*0.1s, options: 0, 1, 2...255;
Data type of output X ( X=1~6 )	Indicates the data type of output X (X=1~6), options: 1 bit, 1 byte;
Data type of output Y ( Y=7~8 )	Indicates the data type of output Y (Y=7~8), options: 1 bit, 1 byte, 2 bytes;
-Output X-	1、 1. When the data type of parameter "Data type of output X" (X=1~8) is "1bit", there are

(X=1~8)	<p>the following parameters:</p> <p>2、① Scene No. for assignment X[1--64, 0=inactive], indicating the scene number of task X(X=1~8)[1--64, 0=inactive], options: 0, 1, 2...64;</p> <p>3、② Output Y for assignment X, indicating setting the switch value of output Y of task X (X=1~8)(Y=1~8), options: Off, On; For example: when X=1, Y=2, it means setting the switch value of output 2 of task 1.</p> <p>4、2. When the data type of parameter "Data type of output X" (X=1~8) is "1 byte", the following parameters are available:</p> <p>5、① Scene No. for assignment X[1--64, 0=inactive], indicating the scene number of task X(X=1~8)[1--64, 0=inactive], options: 0, 1, 2...64;</p> <p>6、② Output Y for assignment X, indicating setting the sending value of output Y of task X (X=1~8)(Y=1~8), options: 0, 1, 2...255; for example: when X=1, Y=2, it means setting the sending value of output 2 of task 1.</p> <p>7、3. When the data type of parameter "Data type of output X" (X=7~8) is "2 byte", the following parameters are available:</p> <p>8、① Scene No. for assignment X[1--64, 0=inactive], indicating the scene number of task X (X=1~8) [1--64, 0=inactive], options: 0, 1, 2...64;</p> <p>9、② Output Y for assignment X, indicating setting the sending value of output Y of task X (X=1~8) (Y=1~8), options: 0, 1, 2...65535; for example: when X=1, Y=2, it means setting the sending value of output 2 of task 1.</p>
---------	--

Note: There are 8 scene modules in total, each scene module has 8 outputs, each output can set 8 different scenes at the same time, and each output can be assigned 64 different scene numbers.

## 6.5 Parameter setting interface Logic Function

“Logic Function” represents the logic function setting interface. There are 8 logic functions available for setting. They are enabled when “Enabled” is selected, as shown in Figure 6.5.

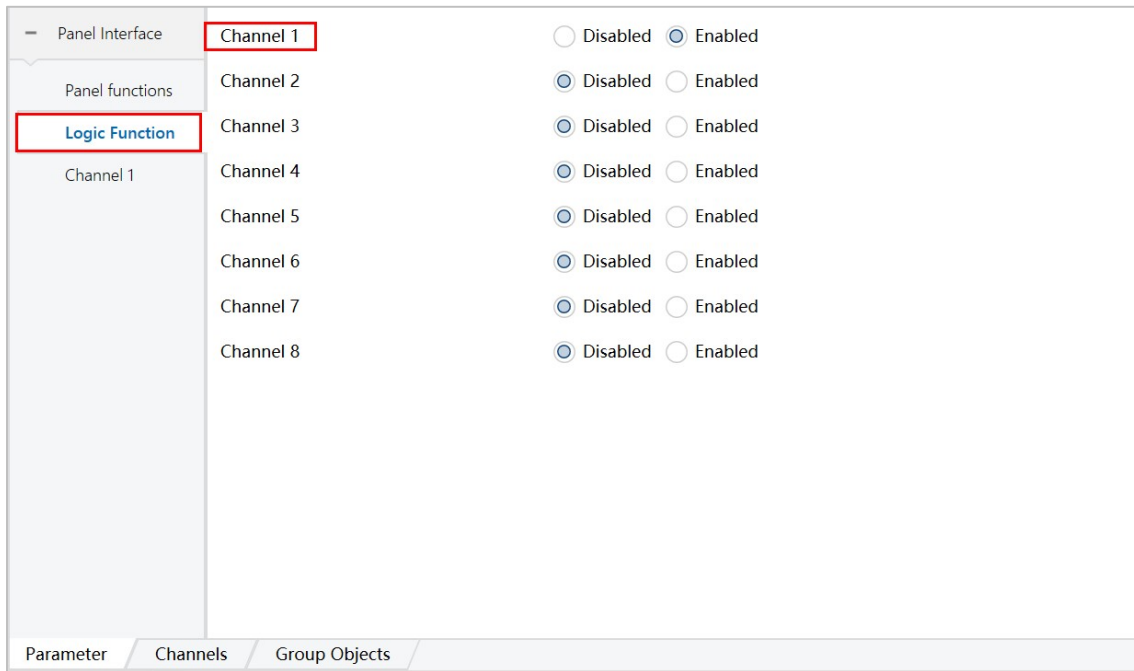

Figure 6.5

1 ) Channel X , indicates channel X (X=1~8), a total of 8 channels are available.

2 ) Function of channel, indicates channel function, options:

- ① OR, AND, XOR, NOR, NAND, XNOR
- ② Threshold comparator
- ④ Data converters

### 6.5.1 OR, AND, XOR, NOR, NAND, XNOR function parameters

When "Function of channel" is selected as "OR, AND, XOR, NOR, NAND, XNOR", the parameters are as follows, as shown in

Figure 6.5.1.

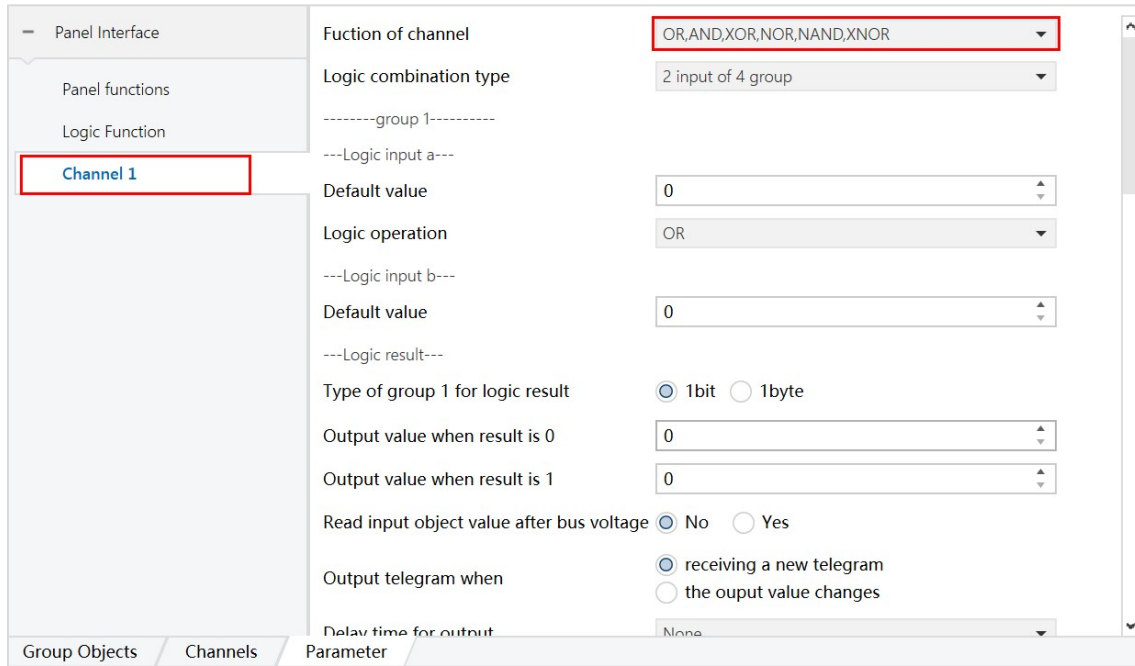

Figure 6.5.1

Parameter	Description
Logic combination type	Indicates a logical combination operation, available options: 2 input of 4 group, 3 input of 2 group + 2 input of 1 group, 4 input of 1 group +2 input of 2 group, 4 input of 2 group, 5 input of 1 group + 3 input of 1 group, 6 input of 1 group +2 input of 1 group, 8 input of 1 group;
group 1	Group 1 ;
Default value	Indicates the default value, options: 0, 1;
Logic operation	Indicates the type of logical operation, options include: OR, AND, XOR, NOR, NAND, XNOR;
Type of group 1 for logic result	Indicates the logical result type of group 1, options: 1bit, 1byte;
Output value when result is 0	Indicates the output value when the result is 0, options: 0, 1;
Output value when result is 1	Indicates the output value when the result is 1, options: 0, 1;
Read input object value after bus voltage	Indicates reading the input objects value after the bus voltage is restarted. Options: No, Yes;

Output telegram when	Indicates the conditions for satisfying the message output. The options are: receiving a new telegram, the output value changes;
Delay time for output	Indicates the output delay time, options: None (no delay), 1s, 3s, 5s, 10s, 15s, 20s, 30s
group X (X=1~4)	Group X (X=1~4). This document takes group 1 (X=1) as an example. The parameters of other groups are the same as above.

### 6.5.2 Threshold comparator function parameters

When "Threshold comparator" is selected in "Fuction of channel", the parameters are as follows, as shown in Figure 6.5.2.

The screenshot shows the configuration interface for the 'Threshold comparator' function. The left sidebar has 'Channel 1' selected. The main area shows the following parameters:

- Fuction of channel:** Threshold comparator
- Threshold value data type:** 4 bit
- Threshold value:** 0
- If object value < threshold value, output 1:** Do not send telegram
- If object value = threshold value, output 2:** Do not send telegram
- If object value != threshold value, output 3:** Do not send telegram
- If object value > threshold value, output 4:** Do not send telegram
- If object value <= threshold value, output 5:** Do not send telegram
- If object value >= threshold value, output 6:** Do not send telegram
- Output telegram when:**  receiving a new telegram,  the ouput value changes
- Delay time for output:** None

Figure 6.5.2

Parameter	Description
Threshold value data type	Indicates the data type of the threshold value. Options include: 4 bit, 1 byte, 2 byte unsigned value, 2 byte float value.
Threshold value	Indicates setting the threshold, options: 0, 1, 2...15;
If object value < threshold	Indicates that if the object value is less than the threshold, the output is 1. The options are:

value, output 1	Do not send telegram, Send value 0, Send value 1.
If object value = threshold value, output 2	Indicates that if the object value is equal to the threshold, then output 2. The options are: Do not send telegram, Send value 0, Send value 1.
If object value $\neq$ threshold value, output 3	If the object value is not equal to the threshold, output 3. The options are: Do not send telegram, Send value 0, Send value 1.
If object value $>$ threshold value, output 4	If the object value is greater than the threshold, 4 is output. The options are: Do not send telegram, Send value 0, Send value 1.
If object value $\leq$ threshold value, output 5	Indicates that if the object value is less than or equal to the threshold, 5 is output. The options are: Do not send telegram, Send value 0, Send value 1.
If object value $\geq$ threshold value, output 6	If the object value is greater than or equal to the threshold, 6 is output. The options are: Do not send telegram, Send value 0, Send value 1.
Output telegram when	Indicates the conditions for satisfying the message output. The options are: receiving a new telegram, the output value changes;
Delay time for output	Indicates the output delay time, options: None (no delay), 1s, 3s, 5s, 10s, 15s, 20s, 30s;

### 6.5.3 Data converters function parameters

When "Data converters" is selected in "Function of channel", the parameters are as follows, as shown in Figure 6.5.3.

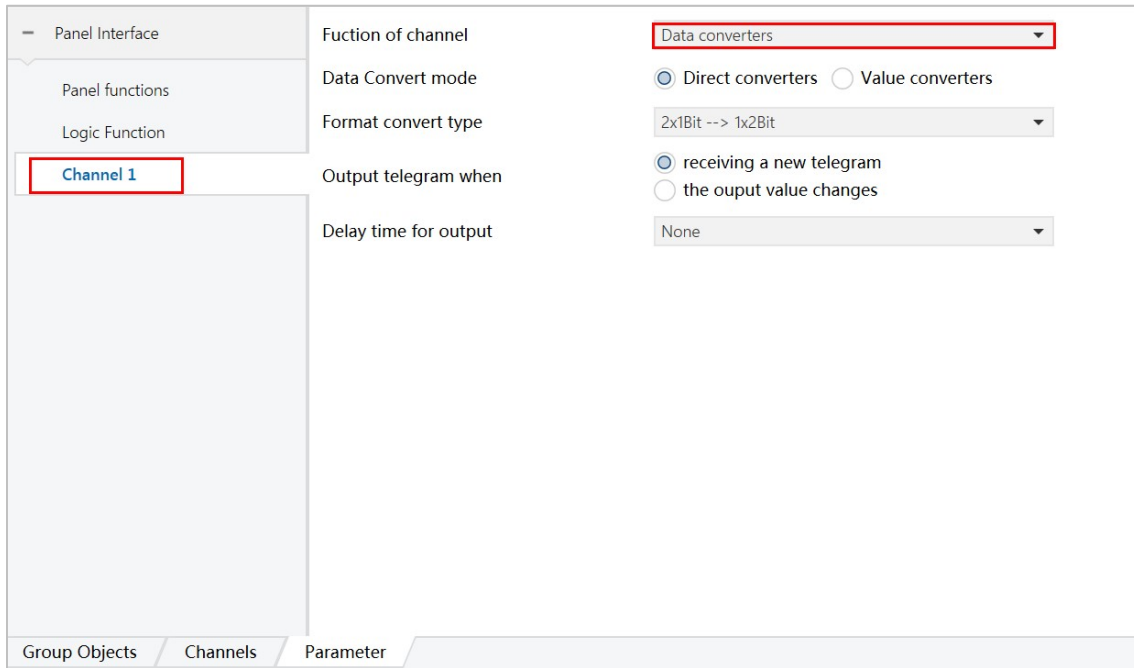

Figure 6.5.3

Parameter	Description
	Indicates the data conversion mode, options: Direct converters, Value converters;
	When "Data Convert mode" selects "Direct converters", there is a parameter: Format convert type, which indicates the format conversion type. The options are: 2x1Bit--> 1x2Bit, 8x1Bit-->1x1Byte, 1x1Byte--> 1x2Byte, 2x2Byte --> 1x4Byte, 1x1Byte--> 1x8Bit, 1x2Byte--> 2x1Byte, 1x4Byte --> 2x2Byte, 1x3Byte --> 3x1Byte, 3x1Byte--> 1x3Byte;
Data Convert mode	When "Value converters" is selected in "Data Convert mode", there are parameters:
Format convert type	<p>① Input type, indicating the input type, options: 1Bit (1 bit), 2Bit (2 bits), 1Byte (1 byte), 2Byte (2 bytes);</p> <p>② Input value, indicating the input value, options: 0, 1;</p> <p>③ Output type, indicating the output type: options: 1Bit (1 bit), 2Bit (2 bits), 1Byte (1 byte), 2Byte (2 bytes);</p> <p>⑤ Output value, indicating the output value, options: 0, 1;</p>

Output telegram when	Indicates the conditions for satisfying the message output. The options are: receiving a new telegram, the output value changes;
Delay time for output	Indicates the output delay time, options: None, 1s, 3s, 5s, 10s, 15s, 20s, 30s;

### 6.6 Device status

The parameter "Device status" indicates the online status of the device and is enabled when "Enabled" is selected, as shown in

Figure 6.6.1.

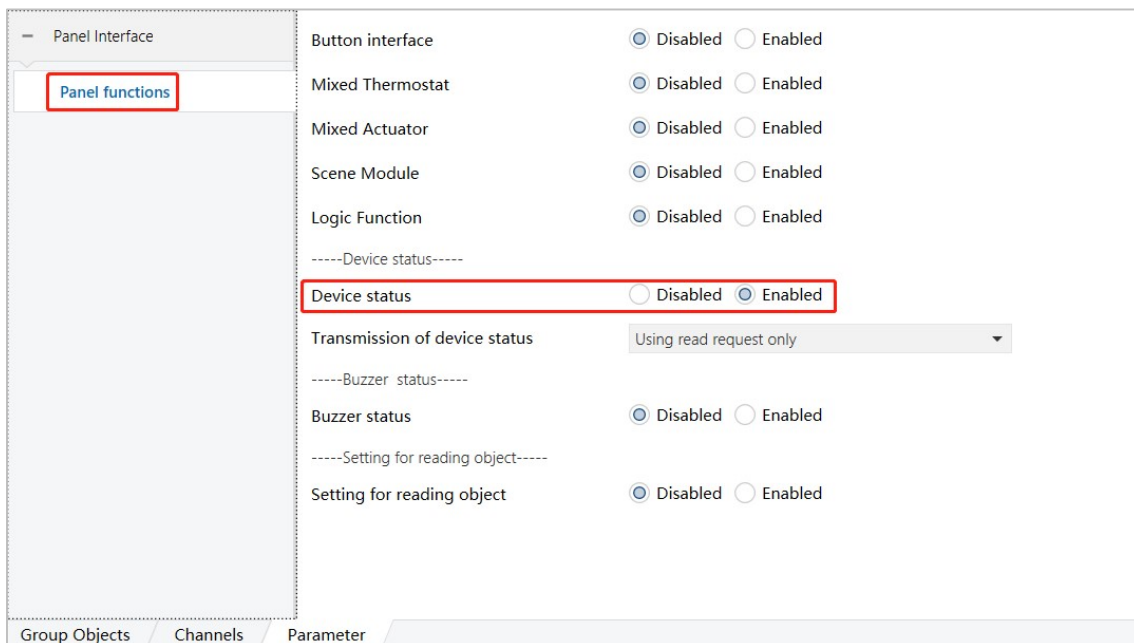

Figure 6.6.1

Transmission of device status indicates the status of the transmission device and the conditions that need to be met. The options are: Using read request only, Transmission in cycles, On change in status.

### 6.7 Buzzer status

The parameter "Buzzer status" indicates the status of the buzzer. It is enabled when "Enabled" is selected, as shown in Figure

6.7.1.

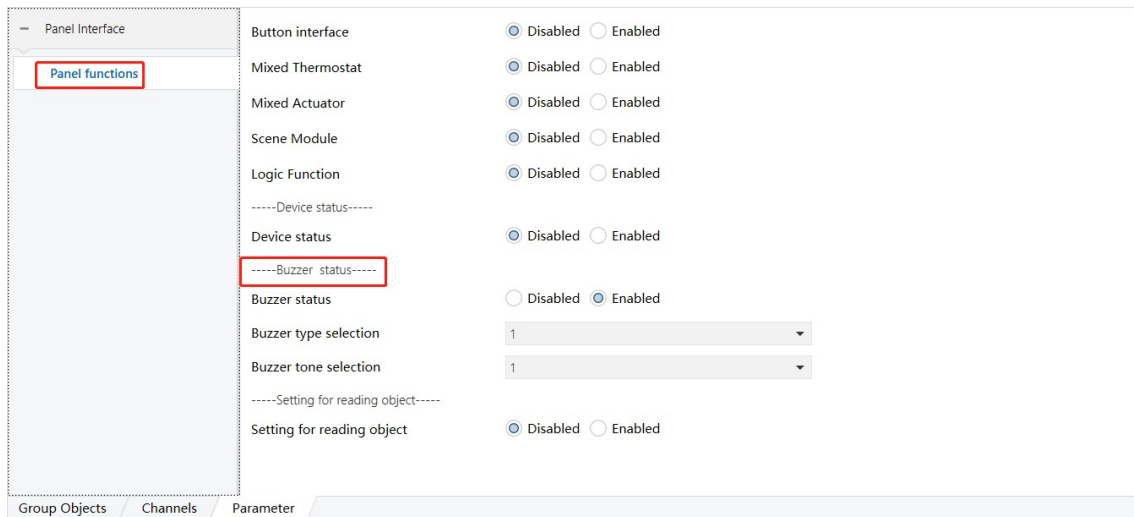

The parameter "Buzzer type selection" indicates the type of buzzer sound, options: 1-7;

The parameter "Buzzer tone selection" indicates the volume of the buzzer sound, options are: 1-7;

Note: When the parameter "Buzzer status" is selected as "Enabled", the default configuration is enabled. The above two parameters do not support configuration yet.

### 6.8 Setting for reading object — **Not available**

## 7. Communication object description

The communication object is the medium for a device to communicate with other devices on the bus, that is, only the communication object can perform bus communication. The following is a detailed introduction to the role of each communication object, taking the first channel "Channel A" of each functional module as an example, and the rest are similar.

Note: In the table properties column below, "C" means that the communication function of the communication object is enabled, "W" means that the value of the communication object can be rewritten through the bus, "R" means that the value of the communication object can be read through the bus, "T" means that the communication object has the transmission function, and "U" means that the value of the communication object can be updated.

### 7.1 Communication object of "Button interface"

#### 7.1.1 Communication object of "Switching"

Number ^	Name	Object Function	Description	Group Address	Length	C	R	W	T	U	Data Type	Priority
1	Channel A, blocking function	Unblocking/Blocking			1 bit	C	R	W	T	-	enable	Low
2	Channel A, switch	On / Off			1 bit	C	R	W	T	-	switch	Low
3	Channel A, status switch	On / Off			1 bit	C	-	W	T	U	switch	Low
6	Channel A, status led for external object 1	On / Off			1 bit	C	-	W	T	U	switch	Low
7	Channel A, status led for external object 2	On / Off			1 bit	C	-	W	T	U	switch	Low
8	Channel A, status led for external object 1	0%..100%			1 byte	C	-	W	T	U	percentage (0..100%)	Low
9	Channel A, status led for external object 2	0%..100%			1 byte	C	-	W	T	U	percentage (0..100%)	Low

Figure 7.1.1

No.	Name	Function	Data	Attributes
1	Channel X, blocking function	Unblocking/Blocking	1 bit	C,R,W,T
<p>This communication object is enabled when the parameter "blocking function" of "Channel X" is set to "Enabled". This communication object is used to turn on/off the blocking function of channel X.</p>				
2	Channel X, switch	On/Off	1 bit	C,R,W,T
<p>This communication object is enabled when "Switching" is selected in the "Select function" parameter of "Channel X". This communication object is used to control the lighting switch operation and send on ("1")/off ("0") messages.</p>				
2	Channel X, switch for pressing	On/Off	1 bit	C,R,W,T
<p>This communication object is enabled when "Switching" is selected in "Select function" of "Channel X", "Pressing/Releasing" is selected in "Switching mode" and "Yes" is selected in "Using another object when releasing". This communication object controls the on/off by pressing the button and sends the on ("1")/off ("0") message.</p>				
2	Channel X, switch for short operation	On/Off	1 bit	C,R,W,T
<p>This communication object is enabled when "Switching" is selected in "Select function" of "Channel X", "Short/Long operation" is selected in "Switching mode", and "Yes" is selected in "Using another object when releasing". This communication object controls the on/off by short pressing the button and sends the on ("1")/off ("0") message.</p>				
2	Channel X, switch for teleg. No.1	On/Off	1 bit	C,R,W,T
<p>This communication object is enabled when "Switching" is selected in the "Select function" parameter of "Channel X" and "Teleg. No.1/No.2" is selected in the "Switching mode". This communication object controls on/off by sending telegram No.1, which sends on ("1")/off ("0") telegrams.</p>				
3	Channel X, status switch	On/Off	1 bit	C,W,T,U
<p>This communication object is enabled when "Switching" is selected in the "Select function" parameter of "Channel X" and "According to the feedback value" is selected in the "Toggle value". This communication object is used to feedback the</p>				

current on/off status of the bound object.				
3	Channel X, switch for releasing	On/Off	1 bit	C,R,W,T
This communication object is enabled when "Switching" is selected in "Select function" of "Channel X", "Pressing/Releasing" is selected in "Switching mode" and "Yes" is selected in "Using another object when releasing". This communication object controls the on/off by releasing the button and sends the on ("1")/off ("0") message.				
3	Channel X, switch for long operation	On/Off	1 bit	C,R,W,T
This communication object is enabled when "Switching" is selected in "Select function" of "Channel X", "Short/Long operation" is selected in "Switching mode", and "Yes" is selected in "Using another object when releasing". This communication object controls the on/off by long pressing the button and sending the on ("1")/off ("0") message.				
3	Channel X, switch for teleg. No.2	On/Off	1 bit	C,R,W,T
This communication object is enabled when "Switching" is selected in the "Select function" parameter of "Channel X" and "Teleg. No.1/No.2" is selected in the "Switching mode". This communication object controls on/off by sending telegram No. 2, which sends on ("1")/off ("0") telegrams.				
Channel X(X=A~L)				

### 7.1.2 Communication object of "Blind"

Number ▲	Name	Object Function	Description	Group Address	Length	C	R	W	T	U	Data Type	Priority
1	Channel A, blocking function	Unblocking/Blocking			1 bit	C	R	W	T	-	enable	Low
2	Channel A, blind for short operation	Position(0%..100%)			1 byte	C	R	W	T	-	percentage (0..100%)	Low
3	Channel A, blind for short operation	Slat(0%..100%)			1 byte	C	R	W	T	-	percentage (0..100%)	Low
4	Channel A, blind for long operation	Position(0%..100%)			1 byte	C	R	W	T	-	percentage (0..100%)	Low
5	Channel A, blind for long operation	Slat(0%..100%)			1 byte	C	R	W	T	-	percentage (0..100%)	Low

Figure 7.1.2

No.	Name	Function	Data length	Attribute
1	Channel X, blocking function	Unblocking/Blocking	1 bit	C,R,W,T
This communication object is enabled when the parameter "blocking function" of "Channel X" is set to "Enabled". This				

communication object is used to turn on/off the blocking function of channel X.				
2	Channel X, blind for short operation	UP/DOWN/STOP	1 bit	C,R,W,T
<p>This communication object is enabled when "Blind" is selected in the "Select function" parameter of "Channel X" and "1 bit" is selected in the "Object type". This communication object controls the up/down/stop of the roller blind by short pressing the button and sends a 1bit type message.</p>				
2	Channel X, blind for short operation	Position(0%..100%)	1 byte	C,R,W,T
<p>This communication object is enabled when "Blind" is selected in the "Select function" parameter of "Channel X", "1 byte" is selected in "Object type", "Enabled" is selected in "Disable/Enable short operation" and "Yes" is selected in "Is the position of blind transmitted". This communication object controls the percentage of the roller blind movement position by short pressing the button.</p>				
3	Channel X, blind for long operation	UP/DOWN/STOP	1 bit	C,R,W,T
<p>This communication object is enabled when "Blind" is selected in the "Select function" parameter of "Channel X", "1 bit" is selected in "Object type", and "Enabled" is selected in "Disable/Enable long operation". This communication object controls the up/down/stop of the roller blind by long pressing the button and sends 1bit type messages.</p>				
3	Channel X, blind for short operation	Slat(0%..100%)	1 byte	C,R,W,T
<p>This communication object is enabled when "Blind" is selected for "Select function" in the "Channel X" parameter, "1 byte" is selected for "Object type", "Enabled" is selected for "Disable/Enable short operation" and "Yes" is selected for "Is the position of Slat transmitted". This communication object controls the percentage of the slat running angle by short pressing the button.</p>				
4	Channel X, blind for long operation	Position(0%.100%)	1 byte	C,R,W,T
<p>This communication object is enabled when "Blind" is selected in the "Select function" parameter of "Channel X", "1 byte" is selected in "Object type", "Enabled" is selected in "Disable/Enable long operation" and "Yes" is selected in "Is the</p>				

position of blind transmitted". This communication object controls the percentage of the roller blind movement position by long pressing the button.

5	Channel X, blind for long operation	Slat(0%..100%)	1 byte	C,R,W,T
---	-------------------------------------	----------------	--------	---------

This communication object is enabled when "Blind" is selected for "Select function" of the "Channel X" parameter, "1 byte" is selected for "Object type", "Enabled" is selected for "Disable/Enable long operation" and "Yes" is selected for "Is the position of Slat transmitted". This communication object controls the percentage of the slat running angle by long pressing the button.

Channel X(X=A~L)

### 7.1.3 Communication object of "Dimming"

Number *	Name	Object Function	Description	Group Address	Length	C	R	W	T	U	Data Type	Priority
1	Channel A, blocking function	Unblocking/Blocking			1 bit	C	R	W	T	-	enable	Low
2	Channel A, switch for dimming	On / Off			1 bit	C	R	W	T	-	switch	Low
4	Channel A, long operation for dimming	Darker/Brighter			4 bit	C	R	W	T	-	dimming control	Low

Figure 7.1.3

No.	Name	Function	Data length	属性
1	Channel X, blocking function	Unblocking/Blocking	1 bit	C,R,W,T

This communication object is enabled when the parameter "blocking function" of "Channel X" is set to "Enabled". This communication object is used to turn on/off the blocking function of channel X.

2	Channel X, switch for dimming	On/Off	1 bit	C,R,W,T
---	-------------------------------	--------	-------	---------

This communication object is enabled when "Dimming" is selected in the "Select function" parameter of "Channel X" and "Relative dimming" is selected in the "Dimming mode". This communication object is used to turn on/off the dimming function and send on ("1")/off ("0") messages.

2	Channel X, short operation for dimming	0..100%	1 byte	C,R,W,T
---	--	---------	--------	---------

This communication object is enabled when "Dimming" is selected in the "Select function" parameter of "Channel X", "Absolute dimming" is selected in the "Dimming mode", and "Enabled" is selected in the "Disable/Enable short operation".

This communication object performs absolute dimming control by short pressing the button.				
3	Channel X, long operation for dimming	0..100%	1 byte	C,R,W,T
<p>This communication object is enabled when "Dimming" is selected in the "Select function" parameter of "Channel X", "Absolute dimming" is selected in the "Dimming mode", and "Enabled" is selected in the "Disable/Enable long operation".</p> <p>This communication object performs absolute dimming control by long pressing the button.</p>				
4	Channel X, long operation for dimming	Darker/Brighter	4 bit	C,R,W,T
<p>This communication object is enabled when "Dimming" is selected in the "Select function" parameter of "Channel X", "Relative dimming" is selected in the "Dimming mode", and "Enabled" is selected in the "Disable/Enable long operation". This communication object performs relative dimming control by long pressing the button.</p>				
Channel X(X=A~L)				

### 7.1.4 "Scene" Communication Object

Number *	Name	Object Function	Description	Group Address	Length	C	R	W	T	U	Data Type	Priority
1	Channel A, blocking function	Unblocking/Blocking			1 bit	C	R	W	T	-	enable	Low
2	Channel A, short operation for scene	Recall/Program			1 byte	C	R	W	T	-	scene control	Low
3	Channel A, long operation for scene	Recall/Program			1 byte	C	R	W	T	-	scene control	Low

Figure 7.1.4

No.	Name	Function	Data length	Attribute
1	Channel X, blocking function	Unblocking/Blocking	1 bit	C,R,W,T
<p>This communication object is enabled when the parameter "blocking function" of "Channel X" is set to "Enabled". This communication object is used to turn on/off the blocking function of channel X.</p>				
2	Channel X, short operation for scene	Recall/Program	1 byte	C,R,W,T
<p>This communication object is enabled when "scene" is selected in the "Select function" parameter of "Channel X". This communication object calls the corresponding scene number by short pressing the button to perform scene control.</p>				

3	Channel X, long operation for scene	Recall/Program	1 byte	C,R,W,T
This communication object is enabled when "scene" is selected in the "Select function" parameter of "Channel X". This communication object calls the corresponding scene number by long pressing the button to perform scene control.				
Channel X(X=A~L)				

### 7.1.5 Communication object of "Value send"

Number ^	Name	Object Function	Description	Group Address	Length	C	R	W	T	U	Data Type	Priority
1	Channel A, blocking function	Unblocking/Blocking			1 bit	C	R	W	T	-	enable	Low
2	Channel A, output 1 for teleg. No. 1	On/Off			1 bit	C	R	W	T	-	switch	Low
4	Channel A, output 1 for teleg. No. 2	On/Off			1 bit	C	R	W	T	-	switch	Low
5	Channel A, output 2 for teleg. No. 2	On/Off			1 bit	C	R	W	T	-	switch	Low

Figure 7.1.5

No.	Name	Function	Data length	Attribute
1	Channel X, blocking function	Unblocking/Blocking	1 bit	C,R,W,T
This communication object is enabled when the parameter "blocking function" of "Channel X" is set to "Enabled". This communication object is used to turn on/off the blocking function of channel X.				
2, 3, 4, 5	Channel X, output 1 for teleg. No. Y	On/Off	1 bit/4bit/1 byte/4 bytes	C,R,W,T
This communication object is enabled when "Value send" is selected in the "Select function" parameter of "Channel X", "Value sending for teleg. No.1/No.2" is selected in "The mode for value sending", and "Enabled" is selected in "Value sending for teleg. No.Y" (Y=1~2). This communication object is used to send values on the bus.				
2	Channel X, output when pressing	On/Off	1 bit/4bit/1 byte/4 bytes	C,R,W,T
This communication object is enabled when "Value send" is selected in "Select function" of the "Channel X" parameter, "Pressing/Releasing" is selected in "The mode for value sending", and "Yes" is selected in "Output when pressing". This communication object sends values by pressing a key.				

2	Channel X, output 1 on short operation	4 bit value	1 bit/4bit/1 byte/4 bytes	C,R,W,T
<p>This communication object is enabled when "Value send" is selected in the "Select function" parameter of "Channel X", "Short/Long operation" is selected in "The mode for value sending", and "Output value 1" is selected in "Output mode on short operation". This communication object sends value 1 by short pressing the button.</p>				
2, 3	Channel X, output Y on short operation	4 bit value	1 bit/4bit/1 byte/4 bytes	C,R,W,T
<p>This communication object is enabled when "Value send" is selected in the "Select function" parameter of "Channel X", "Short/Long operation" is selected in "The mode for value sending", and "Toggle (value 1/value 2)" is selected in "Output mode on short operation". This communication object switches between value 1 and value 2 sending by short pressing the button.</p>				
3	Channel X, output when releasing	On/Off	1 bit/4bit/1 byte/4 byte	C,R,W,T
<p>This communication object is enabled when "Value send" is selected in "Select function" of "Channel X" parameter, "Pressing/Releasing" is selected in "The mode for value sending" and "Yes" is selected in "Output when releasing". This communication object sends value by releasing the button.</p>				
4	Channel A, output 1 on long operation	4 bit value	1 bit/4bit/1 byte/4 byte	C,R,W,T
<p>This communication object is enabled when "Value send" is selected in the "Select function" parameter of "Channel X", "Short/Long operation" is selected in "The mode for value sending", and "Output value 1" is selected in "Output mode on long operation". This communication object sends value 1 by long pressing the button.</p>				
4, 5	Channel X, output Y on long operation	4 bit value	1 bit/4bit/1 byte/4	C,R,W,T

			byte	
<p>This communication object is enabled when "Value send" is selected in the "Select function" parameter of "Channel X", "Short/Long operation" is selected in "The mode for value sending", and "Toggle (value 1/value 2)" is selected in "Output mode on long operation". This communication object switches between value 1 and value 2 sending by long pressing the button.</p>				
Channel X(X=A~L)				

### 7.1.6 Communication objects of "Multiple operation"

Number *	Name	Object Function	Description	Group Address	Length	C	R	W	T	U	Data Type	Priority
1	Channel A, blocking function	Unblocking/Blocking			1 bit	C	R	W	T	-	enable	Low
2	Channel A, output for teleg. No. 1	On / Off			1 bit	C	R	W	T	-	switch	Low
3	Channel A, output for teleg. No. 2	4 bit value			4 bit	C	R	W	T	-	dimming control	Low
4	Channel A, output for teleg. No. 3	1 byte value			1 byte	C	R	W	T	-	percentage (0..100%)	Low
5	Channel A, output for teleg. No. 4	2 byte value			2 bytes	C	R	W	T	-	pulses	Low

Figure 7.1.6

No.	Name	Function	Data length	Attribute
1	Channel X, blocking function	Unblocking/Blocking	1 bit	C,R,W,T
<p>This communication object is enabled when the parameter "blocking function" of "Channel X" is set to "Enabled". This communication object is used to turn on/off the blocking function of channel X.</p>				
2, 3, 4, 5	Channel X, output for teleg. No. Y	On/Off	1 bit/4bit/1 byte/4 byte	C,R,W,T
<p>This communication object is enabled when "Multiple operation" is selected for "Select function" of the "Channel X" parameter, "Enabled" is selected for "Short operation is", and "Object type for telegram No.Y" (Y=1~4) is not selected for "Disabled". This communication object sends values by short pressing the button.</p>				
Channel X(X=A~L)				

## 7.1.7 Communication object of "Shift function"

Number *	Name	Object Function	Description	Group Address	Length	C	R	W	T	U	Data Type	Priority
1	Channel A, blocking function	Unblocking/Blocking			1 bit	C	R	W	T	-	enable	Low
2	Channel A, object 1 for shift function	On / Off			1 bit	C	R	W	T	-	switch	Low
3	Channel A, object 2 for shift function	On / Off			1 bit	C	R	W	T	-	switch	Low
4	Channel A, object 3 for shift function	On / Off			1 bit	C	R	W	T	-	switch	Low
5	Channel A, object 4 for shift function	On / Off			1 bit	C	R	W	T	-	switch	Low

Figure 7.1.7

No.	Name	Function	Data length	Attribute
1	Channel X, blocking function	Unblocking/Blocking	1 bit	C,R,W,T
<p>This communication object is enabled when the parameter "blocking function" of "Channel X" is set to "Enabled". This communication object is used to turn on/off the blocking function of channel X.</p>				
2、 3、 4、 5	Channel X, object Y for shift function	On/Off	1 bit	C,R,W,T
<p>This communication object is enabled when the parameter "Select function" of "Channel X" selects "Shift function" and "Shift type" selects "Shift by object". This communication object is used to output the value of the object shift function on the bus. (Y=1~4)</p>				
2	Channel X, output for shift function	1 byte value	1 byte/2 byte	C,R,W,T
<p>This communication object is enabled when "Shift function" is selected as "Select function" in the parameter of "Channel X" and "Shift by step value" is selected as "Shift type" or "Shift by setting value" is selected as "Shift type". This communication object is used to output the value of the function of shifting by step value/shifting by setting value on the bus.</p>				
3	Channel X, status for shift function	1 byte value	1 byte/2 byte	C,W,T,U
<p>This communication object is enabled when "Status feedback object" is selected as "Enabled" under the premise that "Shift function" is selected as "Select function" of the "Channel X" parameter and "Shift by step value" or "Shift type" is selected as "Shift by setting value". This communication object is used to feedback the value output status of the shift by step value/shift by setting value function on the bus.</p>				
Channel X(X=A~L)				

## 7.1.8 Communication object of "RGB dimming"

Number *	Name	Object Function	Description	Group Address	Length	C	R	W	T	U	Data Type	Priority
1	Channel A, blocking function	Unblocking/Blocking			1 bit	C	R	W	T	-	enable	Low
2	Channel A, Red dimming value	0..255			1 byte	C	R	W	T	-	percentage (0..100%)	Low
3	Channel A, Green dimming value	0..255			1 byte	C	R	W	T	-	percentage (0..100%)	Low
4	Channel A, Blue dimming value	0..255			1 byte	C	R	W	T	-	percentage (0..100%)	Low
5	Channel A, White dimming value	0..255			1 byte	C	R	W	T	-	percentage (0..100%)	Low

Figure 7.1.8

No	Name	Function	Data length	Attribute
1	Channel X, blocking function	Unblocking/Blocking	1 bit	C,R,W,T
<p>This communication object is enabled when the parameter "blocking function" of "Channel X" is set to "Enabled". This communication object is used to turn on/off the blocking function of channel X.</p>				
2	Channel X, RGB dimming value	0..255	3 bytes	C,R,W,T
<p>This communication object is enabled when "RGB dimming" is selected in "Select function" of "Channel X", "RGB dimming type" is selected as "RGB" and "Object type (RGB)" is selected as "1x3byte". This communication object is used for RGB dimming of 1x3byte type.</p>				
2	Channel X, Red dimming value	0..255	1 bytes	C,R,W,T
<p>This communication object is enabled when "RGB dimming" is selected in "Select function" of "Channel X" parameter, "RGB dimming type" is selected as "RGB" and "Object type (RGB)" is selected as "3x1byte" or "RGB dimming type" is selected as "RGBW" and "Object type (RGBW)" is selected as "4x1byte". This communication object is used to output the red dimming value of RGB.</p>				
2	Channel X, RGBW dimming value	0..255	3 bytes	C,R,W,T
<p>This communication object is enabled when "RGB dimming" is selected in the "Select function" parameter of "Channel X", "RGB dimming type" is selected as "RGBW", and "Object type (RGBW)" is selected as "1x6byte". This communication object is used for RGBW dimming of 1x6 byte type.</p>				
3	Channel X, Green dimming value	0..255	1 bytes	C,R,W,T

This communication object is enabled when "RGB dimming" is selected in the "Select function" parameter of "Channel X", "RGB dimming type" is selected as "RGB" and "Object type (RGB)" is selected as "3x1byte" or "RGB dimming type" is selected as "RGBW" and "Object type (RGBW)" is selected as "4x1byte". This communication object is used to output the green dimming value of RGB.

4	Channel X, Blue dimming value	0..255	1 bytes	C,R,W,T
---	-------------------------------	--------	---------	---------

This communication object is enabled when "RGB dimming" is selected in the "Select function" parameter of "Channel X", "RGB dimming type" is selected as "RGB" and "Object type (RGB)" is selected as "3x1byte" or "RGB dimming type" is selected as "RGBW" and "Object type (RGBW)" is selected as "1x6byte". This communication object is used to output the blue dimming value of RGB.

5	Channel X, White dimming value	0..255	1 bytes	C,R,W,T
---	--------------------------------	--------	---------	---------

This communication object is enabled when "RGB dimming" is selected in the "Select function" parameter of "Channel X", "RGB dimming type" is selected as "RGBW", and "Object type (RGBW)" is selected as "4x1byte". This communication object is used to output the white dimming value of RGB.

Channel X(X=A~L)				
------------------	--	--	--	--

### 7.1.9 Communication object of "Delay mode"

Number *	Name	Object Function	Description	Group Address	Length	C	R	W	T	U	Data Type	Priority
1	Channel A, blocking function	Unblocking/Blocking			1 bit	C	R	W	T	-	enable	Low
2	Channel A, output 1 on short operation	On / Off			1 bit	C	R	W	T	-	switch	Low
3	Channel A, output 2 on short operation	On / Off			1 bit	C	R	W	T	-	switch	Low
4	Channel A, output 1 on long operation	On / Off			1 bit	C	R	W	T	-	switch	Low
5	Channel A, output 2 on long operation	On / Off			1 bit	C	R	W	T	-	switch	Low

Figure 7.1.9

No.	Name	Function	Data length	Attribute
1	Channel X, blocking function	Unblocking/Blocking	1 bit	C,R,W,T

This communication object is enabled when the parameter "blocking function" of "Channel X" is set to "Enabled". This communication object is used to turn on/off the blocking function of channel X.

2	Channel X, output 1 on short operation	1 bit/4bit/1 byte/2 byte value	1 bit/4bit/1 byte/2 bytes	C,R,W,T
<p>This communication object is enabled when "Delay mode" is selected in the "Select function" parameter of "Channel X" and "Enabled" is selected in "Short operation". This communication object is used to set the delay time for output 1 value to be sent by short pressing the button.</p>				
3	Channel X, output 2 on short operation	1 bit/4bit/1 byte/2 byte value	1 bit/4bit/1 byte/2 bytes	C,R,W,T
<p>This communication object is enabled when "Delay mode" is selected in the "Select function" parameter of "Channel X" and "Enabled" is selected in "Short operation". This communication object is used to set the delay time of output 2 value sent by short pressing the button.</p>				
4	Channel X, output 1 on long operation	1 bit/4bit/1 byte/2 byte value	1 bit/4bit/1 byte/2 bytes	C,R,W,T
<p>This communication object is enabled when "Delay mode" is selected in the "Select function" parameter of "Channel X" and "Enabled" is selected in "long operation". This communication object is used to set the delay time for output 1 value to be sent by long pressing the button.</p>				
5	Channel X, output 2 on long operation	1 bit/4bit/1 byte/2 byte value	1 bit/4bit/1 byte/2 bytes	C,R,W,T
<p>This communication object is enabled when "Delay mode" is selected in the "Select function" parameter of "Channel X" and "Enabled" is selected in "long operation". This communication object is used to set the delay time of output 2 value sent by long pressing the button.</p>				
Channel X(X=A~L)				

#### 7.1.10 Communication objects for "Operation for local thermostat"

—This function has no communication object

## 7.1.11 Communication object of "Operation for local actuator"

—This function has no communication object

## 7.1.12 Communication object of "Status LED"

Number *	Name	Object Function	Description	Group Address	Length	C	R	W	T	U	Data Type	Priority
1	Channel A, blocking function	Unblocking/Blocking			1 bit	C	R	W	T	-	enable	Low
2	Channel A, output 1 on short operation	On / Off			1 bit	C	R	W	T	-	switch	Low
3	Channel A, output 2 on short operation	On / Off			1 bit	C	R	W	T	-	switch	Low
4	Channel A, output 1 on long operation	On / Off			1 bit	C	R	W	T	-	switch	Low
5	Channel A, output 2 on long operation	On / Off			1 bit	C	R	W	T	-	switch	Low

Figure 7.1.12

No.	Name	Function	Data length	Attribute
1	Channel X, blocking function	Unblocking/Blocking	1 bit	C,R,W,T
<p>This communication object is enabled when the parameter "blocking function" of "Channel X" is set to "Enabled". This communication object is used to turn on/off the blocking function of channel X.</p>				
6	Channel X, status led for external object 1	On/Off	1 bit	C,W,T,U
<p>This communication object is enabled when the parameter "Status LED" of "Channel X" is selected as "Enabled" and "external object 1 for 1bit" is selected as "Enabled". This communication object is used to feedback the status of 1bit external object 1.</p>				
7	Channel X, status led for external object 2	On/Off	1 bit	C,W,T,U
<p>This communication object is enabled when the parameter "Status LED" of "Channel X" is selected as "Enabled" and "external object 2 for 1bit" is selected as "Enabled". This communication object is used to feedback the status of 1bit external object 2.</p>				
8	Channel X, status led for external object 1	0%..100%	1 byte	C,W,T,U
<p>This communication object is enabled when the parameter "Status LED" of "Channel X" is selected as "Enabled" and</p>				

"external object 1 for 1byte" is selected as "Enabled". This communication object is used to feedback the status of 1byte external object 1.

9	Channel X, status led for external  object 2	0%..100%	1 byte	C,W,T,U
---	--	----------	--------	---------

This communication object is enabled when "Enabled" is selected for "Status LED" of the "Channel X" parameter and "Enabled" is selected for "external object 1 for 1byte". This communication object is used to feedback the status of 1byte external object 2.

Channel X(X=A~L)

### 7.1.13 Communication partner of "LED settings"

Number *	Name	Object Function	Description	Group Address	Length	C	R	W	T	U	Data Type	Priority
109	Overwrite brightness, Status LED	0%..100%			1 byte	C	R	W	T	-	percentage (0..100%)	Low
111	Overwrite brightness, Waking backlight	0%..100%			1 byte	C	R	W	T	-	percentage (0..100%)	Low
114	Overwrite brightness, Sleeping backlight	0%..100%			1 byte	C	R	W	T	-	percentage (0..100%)	Low
116	Master output, Control other's backlight	On / Off			1 bit	C	R	-	T	-	switch	Low
117	Input-triggering, Waking backlight	On / Off			1 bit	C	R	W	T	-	switch	Low
118	Triggering output, Waking backlight	On / Off			1 bit	C	R	-	T	-	switch	Low

Figure 7.1.13

No.	Name	Function	Data length	Attribute
109	Overwrite brightness, Status LED	0%...100%	1 byte	C,R,W,T

This communication object is enabled when the parameter "blocking function" of "Channel X" is set to "Enabled". This communication object is used to turn on/off the blocking function of channel X.

111	Overwrite brightness, Waking  backlight	0%...100%	1 byte	C,R,W,T
-----	---	-----------	--------	---------

This communication object is enabled when the parameter "Configuration" of "LED settings" is set to "Normal mode" and "Overwrite brightness of backlight LED via object" is set to "Yes". This object is used to rewrite the backlight brightness during wake-up. (Note: This parameter is in the Backlight during wake-up column).

111	Overwrite brightness, Waking	0%...100%	1 byte	C,R,W,T
-----	------------------------------	-----------	--------	---------

	backlight in the day			
<p>This communication object is enabled when the parameter "Configuration" of "LED settings" is set to "Day / Night mode" and "Overwrite brightness of backlight LED via object" is set to "Yes". This object is used to rewrite the backlight brightness for daytime wake-up. (Note: This parameter is in the In the day column).</p>				
112	Overwrite brightness, Waking  backlight at night	0%...100%	1 byte	C,R,W,T
<p>This communication object is enabled when the parameter "Configuration" of "LED settings" is selected as "Day / Night mode" and "Overwrite brightness of backlight LED via object" is selected as "Yes". This object is used to rewrite the backlight brightness when waking up at night. (Note: This parameter is in the At night column).</p>				
113	Input from master, Control own  backlight	On/Off	1 bit	C,R,T
<p>This communication object is enabled when "Normal mode" is selected for the parameter "Configuration" of "LED settings" and "delay according to master device" is selected for "Delay time after waking backlight". This object is used to delay the backlight function of the panel according to the master device.</p>				
114	Overwrite brightness, Sleeping  backlight	0%...100%	1 byte	C,R,W,T
<p>This communication object is enabled when "Normal mode" is selected in the parameter "Configuration" of "LED settings" and "Yes" is selected in "Overwrite brightness of backlight LED via object". This object is used to rewrite the backlight brightness during sleep. (Note: This parameter is in the Backlight during sleep column).</p>				
114	Overwrite brightness, Sleeping  backlight in the day	0%...100%	1 byte	C,R,W,T
<p>This communication object is enabled when "Day / Night mode" is selected in the parameter "Configuration" of "LED</p>				

<p>settings" and "Yes" is selected in "Overwrite brightness of backlight LED via object". This object is used to rewrite the backlight brightness during daytime sleep. (Note: This parameter is in the In the day column).</p>				
115	Overwrite brightness, Sleeping  backlight at night	0%...100%	1 byte	C,R,W,T
<p>This communication object is enabled when the parameter "Configuration" of "LED settings" is selected as "Day / Night mode" and "Overwrite brightness of backlight LED via object" is selected as "Yes". This object is used to rewrite the backlight brightness during sleep at night. (Note: This parameter is in the At night column).</p>				
116	Master output, Control other's  backlight	On/Off	1 bit	C,R,T
<p>This communication object is enabled when "Normal mode" is selected for the parameter "Configuration" in the "LED settings" and "Yes" is selected for "Master output for controlling other's backlight". This object is used to control the backlight function of the slave panel.</p>				
117	Input-triggering, Waking backlight	On/Off	1 bit	C,R,W,T
<p>This communication object is enabled when "Normal mode" is selected in the parameter "Configuration" of "LED settings" and "Yes" is selected in "Wake up backlight via object". This object is used to wake up the backlight via the group address object.</p>				
118	Triggering output, Waking backlight	On/Off	1 bit	C,R,T
<p>This communication object is enabled when "Yes" is selected for the parameter "Output triggering signal for waking backlight" in "LED settings". This object is used to output the On/Off trigger value on the bus when the backlight is awakened.</p>				
119	Day/Night mode, Change over	Day/Night	1 bit	C,W,T , U
<p>This communication object is enabled when "Day / Night mode" is selected in the parameter "Configuration" of "LED settings". This object is used to switch the LED day/night mode.</p>				

## 7.2 Communication object of “ Mixed Thermostat”

### 7.2.1 “Air conditioning” Mode

Number *	Name	Object Function	Description	Group Address	Length	C	R	W	T	U	Data Type	Priority
129	Thermostat, blocking function	Unblocking/Blocking			1 bit	C	R	W	T	-	enable	Low
133	Air conditioning, Switch	On/Off-Output			1 bit	C	R	-	T	-	switch	Low
134	Air conditioning, Feedback switch	On/Off-Input			1 bit	C	-	W	T	U	switch	Low
135	Air conditioning, Operating mode	1byte-Output			1 byte	C	R	-	T	-	HVAC control mode	Low
136	Air conditioning, Feedback operating mode	1byte-Input			1 byte	C	-	W	T	U	HVAC control mode	Low
137	Air conditioning, Fan speed	1byte-Output			1 byte	C	R	-	T	-	percentage (0..100%)	Low
138	Air conditioning, Feedback fan speed	1byte-Input			1 byte	C	-	W	T	U	percentage (0..100%)	Low
139	Air conditioning, Setting temperature	2byte-Output			2 bytes	C	R	-	T	-	temperature (°C)	Low
140	Air conditioning, Feedback Setting temperature	2byte-Input			2 bytes	C	-	W	T	U	temperature (°C)	Low
141	Air conditioning, Recv actual temperature	2 byte			2 bytes	C	-	W	T	U	temperature (°C)	Low

Figure 7.2.1

No.	Name	Function	Data length	Attribute
129	Thermostat, blocking function	Unblocking/Blocking	1 bit	C,R,W,T
<p>This communication object is enabled when "Enabled" is selected for the parameter "Blocking function" of "Mixed Thermostat". This communication object is used to turn on/off the blocking function of the thermostat.</p>				
133	Air conditioning, Switch	On/Off-Output	1 bit	C,R,T
<p>This communication object is enabled when the parameter "Air conditioning" of "Mixed Thermostat" is set to "Air conditioning". This communication object is used to control the switch of the air conditioning gateway. When the communication object sends the value "1/0", the air conditioning gateway will perform the preset "on/off" operation.</p>				
134	Air conditioning, Feedback switch	On/Off-Input	1 bit	C,W,T,U
<p>This communication object is enabled when the parameter "Air conditioning" of "Mixed Thermostat" is set to "Air conditioning". This communication object is used to feedback the switch status of the air conditioning gateway.</p>				
135	Air conditioning, Operating mode	1byte-Output	1 byte	C,R,T
<p>This communication object is enabled when "Air conditioning" is selected in the "Mixed Thermostat" parameter "Air conditioning". This communication object is used to switch the operating mode. The communication object sends the preset value to switch the operating mode of the air conditioning gateway (heating mode, cooling mode, air supply mode, dehumidification mode, etc.).</p>				

136	Air conditioning, Feedback Operating mode	1byte-Input	1 byte	C,W,T,U
<p>This communication object is enabled when the parameter "Air conditioning" of "Mixed Thermostat" is set to "Air conditioning". This communication object is used to feedback the operation mode, bind the feedback object, and use the received feedback value to change the operation mode indication of the temperature control panel. When the communication object receives the corresponding value, the temperature control panel indicates the corresponding operation mode.</p>				
137	Air conditioning, Fan speed	1byte-Output	1 byte	C,R,T
<p>This communication object is enabled when the parameter "Air conditioning" of "Mixed Thermostat" is set to "Air conditioning". This communication object is used to control the air conditioning wind speed. The communication object sends the preset value to control the air conditioning.风速。</p>				
138	Air conditioning, Feedback fan speed	1byte-Input	1 byte	C,W,T,U
<p>This communication object is enabled when "Air conditioning" is selected in the "Mixed Thermostat" parameter "Air conditioning". This communication object is used to feedback the air conditioning wind speed. By binding the feedback object, the air conditioning wind speed indication on the temperature control panel is changed using the received feedback value. When the communication object receives the corresponding value, the temperature control panel indicates the corresponding air conditioning wind speed.</p>				
139	Air conditioning, Setting temperature	2byte-Output	2 bytes	C,R,T
<p>This communication object is enabled when "Air conditioning" is selected in the parameter "Air conditioning" of "Mixed Thermostat". This communication object is used to control the air conditioning temperature. The communication object sends the temperature value to control the temperature of the air conditioning gateway. The temperature can be set in the range of 16°C~32°C.</p>				
140	Air conditioning, Feedback Setting temperature	2byte-Input	2 bytes	C,W,T,U
<p>This communication object is enabled when "Air conditioning" is selected in the "Mixed Thermostat" parameter "Air</p>				

conditioning". This communication object is used to feedback the current air conditioning temperature value, bind the feedback object, and use the received feedback value to change the air conditioning temperature indication of the temperature control panel. When the communication object receives the corresponding value, the temperature control panel indicates the corresponding temperature value.

141	Air conditioning, Recv actual temperature	2byte	2 bytes	C,W,T,U
-----	---	-------	---------	---------

This communication object is enabled when "Air conditioning" is selected in the parameter "Air conditioning" of "Mixed Thermostat". This communication object is used to display the actual temperature value of the external sensor.

### 7.2.2 "HVAC" Mode

Number *	Name	Object Function	Description	Group Address	Length	C	R	W	T	U	Data Type	Priority
142	HVAC, Cooling control	1byte			1 byte	C	R	-	T	-	percentage (0..100%)	Low
144	HVAC, Fan speed low	On / Off			1 bit	C	R	-	T	-	switch	Low
145	HVAC, Fan speed medium	On / Off			1 bit	C	R	-	T	-	switch	Low
146	HVAC, Fan speed high	On / Off			1 bit	C	R	-	T	-	switch	Low
147	HVAC, Recv actual temperature	2 byte			2 bytes	C	-	W	T	U	temperature (°C)	Low
148	HVAC, Cooling and heating mode	Cooling/Heating-Input			1 bit	C	-	W	T	U	cooling/heating	Low
149	HVAC, Cooling and heating mode	Cooling/Heating-Output			1 bit	C	R	-	T	-	cooling/heating	Low
150	HVAC, Setting HVAC mode	1byte-Input			1 byte	C	-	W	T	U	HVAC control mode	Low
151	HVAC, Setting HVAC mode	1byte-Output			1 byte	C	R	-	T	-	HVAC control mode	Low
152	HVAC, Setting fan speed	1byte-Input			1 byte	C	-	W	T	U	percentage (0..100%)	Low
153	HVAC, Setting fan speed	1byte-Output			1 byte	C	R	-	T	-	percentage (0..100%)	Low
154	HVAC, Setting function switch	On/Off-Input			1 bit	C	-	W	T	U	switch	Low
155	HVAC, Setting function switch	On/Off-Output			1 bit	C	R	-	T	-	switch	Low
156	HVAC, Setting temperature	2 byte-Input			2 bytes	C	-	W	T	U	temperature (°C)	Low
157	HVAC, Setting temperature	2 byte-Output			2 bytes	C	R	-	T	-	temperature (°C)	Low

Figure 7.2.2

No.	Name	Function	Data length	Attribute
142	HVAC, Cooling control	On/Off	1 bit/1 byte	C,R,T

This communication object is enabled when "HVAC" is selected as "Air conditioning" in the "Mixed Thermostat" parameter, "Enabled" is selected as "Cooling" in "Cooling/Heating control", and "Cooling" is selected as "Type of HVAC control". This communication object is used to send the cooling status of the fan coil unit.

142	HVAC, Cooling/Heating control	On/Off	1 bit/1 byte	C,R,T
-----	-------------------------------	--------	--------------	-------

This communication object is enabled when "HVAC" is selected as "Air conditioning" in the "Mixed Thermostat" parameter, "Enabled" is selected as "Cooling/Heating control", "Heating and Cooling" is selected as "Type of HVAC control" and "2 pipes system" is selected as "Control system". This communication object is used to send the cooling/heating status

of the (2-pipe) fan coil unit.				
143	HVAC, Heating control	On/Off	1 bit/1 byte	C,R,T
<p>This communication object is enabled when "HVAC" is selected as "Air conditioning" in the "Mixed Thermostat" parameter, "Enabled" is selected as "Cooling/Heating control", "Heating" is selected as "Type of HVAC control" or "Heating and Cooling" is selected as "Type of HVAC control", and "4 pipes system" is selected as "Control system". This communication object is used to send the heating status of the (4-pipe) fan coil unit.</p>				
144	HVAC, Control fan speed	On/Off	1 byte	C,R,T
<p>This communication object is enabled when "HVAC" is selected for "Air conditioning" of the "Mixed Thermostat" parameter, "Enabled" is selected for "Fan speed control" and "1 byte" is selected for "Datatype for fan speed control". This communication object is used to send the fan speed status of the fan coil unit.</p>				
144	HVAC, Fan speed low	On/Off	1 bit	C,R,T
<p>This communication object is enabled when "HVAC" is selected for "Air conditioning" of the "Mixed Thermostat" parameter, "Enabled" is selected for "Fan speed control" and "1 bit" is selected for "Datatype for fan speed control". This communication object is used to send the low wind speed status of the fan coil unit.</p>				
145	HVAC, Fan speed medium	On/Off	1 bit	C,R,T
<p>This communication object is enabled when "HVAC" is selected for "Air conditioning" of the "Mixed Thermostat" parameter, "Enabled" is selected for "Fan speed control" and "1 bit" is selected for "Datatype for fan speed control". This communication object is used to send the fan coil unit's medium wind speed status.</p>				
146	HVAC, Fan speed high	On/Off	1 bit	C,R,T
<p>This communication object is enabled when "HVAC" is selected for "Air conditioning" of the "Mixed Thermostat" parameter, "Enabled" is selected for "Fan speed control" and "1 bit" is selected for "Datatype for fan speed control". This communication object is used to send the high wind speed status of the fan coil unit.</p>				

147	HVAC, Recv actual temperature	2 byte	2 bytes	C,W,T,U
<p>This communication object is enabled when "HVAC" is selected as the "Air conditioning" parameter of "Mixed Thermostat" and "External sensor" is selected as the "Indoor temperature source". This communication object is used to feed back the actual temperature message received by the fan coil to the bus.</p>				
148	HVAC, Cooling and heating mode	Cooling/Heating-Input	1 bit/1 bytes	C,W,T,U
<p>This communication object is enabled when "HVAC" is selected for "Air conditioning" in the "Mixed Thermostat" parameter and "Enabled" is selected for "Setting cooling/heating mode". This communication object is used to feed back the cooling/heating mode message of the fan coil to the bus.</p>				
149	HVAC, Cooling and heating mode	Cooling/Heating-Output	1 bit/1 bytes	C,R,T
<p>This communication object is enabled when "HVAC" is selected for "Air conditioning" in the "Mixed Thermostat" parameter and "Enabled" is selected for "Setting cooling/heating mode". This communication object is used to send the cooling/heating mode status of the fan coil unit.</p>				
150	HVAC, Setting HVAC mode	1byte-Input	1 byte	C,W,T,U
<p>This communication object is enabled when "HVAC" is selected for "Air conditioning" in the "Mixed Thermostat" parameter and "Enabled" is selected for "Setting HVAC mode". This communication object uses 1 byte to feed back the fan coil mode message to the bus.</p>				
151	HVAC, Setting HVAC mode	1byte-Output	1 byte	C,R,T
<p>This communication object is enabled when "HVAC" is selected for "Air conditioning" in the "Mixed Thermostat" parameter and "Enabled" is selected for "Setting HVAC mode". This communication object is used to send the status of the fan coil mode through 1 byte.</p>				
152	HVAC, Setting fan speed	1byte-Input	1 byte	C,W,T,U
<p>This communication object is enabled when "HVAC" is selected for "Air conditioning" of the "Mixed Thermostat" parameter and "Enabled" is selected for "Setting fan speed". This communication object uses 1 byte to feed back the fan coil</p>				

wind speed message to the bus.				
153	HVAC, Setting fan speed	1byte-Output	1 byte	C,R,T
<p>This communication object is enabled when "HVAC" is selected for "Air conditioning" of the "Mixed Thermostat" parameter and "Enabled" is selected for "Setting fan speed". This communication object is used to send the status of the fan coil speed through 1 byte.</p>				
154	HVAC, Setting function switch	On/Off-Input	1 bit	C,W,T,U
<p>This communication object is enabled when "HVAC" is selected for "Air conditioning" in the "Mixed Thermostat" parameter and "Enabled" is selected for "Setting function switch". This communication object is used to feed back the fan coil on/off message to the bus via 1 bit.</p>				
155	HVAC, Setting function switch	On/Off-Output	1 bit	C,R,T
<p>This communication object is enabled when "HVAC" is selected for "Air conditioning" in the "Mixed Thermostat" parameter and "Enabled" is selected for "Setting function switch". This communication object is used to send the fan coil on/off status through 1 bit.</p>				
156	HVAC, Setting temperature	2byte-Input	2 bytes	C,W,T,U
<p>This communication object is enabled when the parameter "Air conditioning" of "Mixed Thermostat" is set to "HVAC" and "Setting temperature" is set to "Enabled". This communication object is used to feed back the fan coil temperature setting message to the bus via 2 bytes.</p>				
157	HVAC, Setting temperature	2byte-Output	2 bytes	C,R,T
<p>This communication object is enabled when "HVAC" is selected for "Air conditioning" of the "Mixed Thermostat" parameter and "Enabled" is selected for "Setting temperature". This communication object is used to send the status of the fan coil setting temperature through 2 bytes.</p>				

### 7.2.3 "Floor heating" Mode

Number *	Name	Object Function	Description	Group Address	Length	C	R	W	T	U	Data Type	Priority
158	Floor heating, Relay control	On / Off			1 bit	C	R	-	T	-	switch	Low
159	Floor heating, Actual temperature	2 byte-Input			2 bytes	C	-	W	T	U	temperature (°C)	Low
160	Floor heating, Setting temperature	2 byte-Input			2 bytes	C	-	W	T	U	temperature (°C)	Low
161	Floor heating, Setting temperature	2 byte-Output			2 bytes	C	R	-	T	-	temperature (°C)	Low
162	Floor heating, Function switch	On/Off-Input			1 bit	C	-	W	T	U	switch	Low
163	Floor heating, Function switch	On/Off-Output			1 bit	C	R	-	T	-	switch	Low

Figure 7.2.3

No.	Name	Function	Data length	Attribute
158	Floor heating, Relay control	On/Off	1 bit	C,R,T
<p>This communication object is enabled when the parameter "Floor heating" of the "Mixed Thermostat" is selected as "Enabled" and the parameter "Relay switch" is selected as "Enabled". This communication object is used to send the on/off status of the relay.</p>				
159	Floor heating, Actual temperature	2byte-Input	2 bytes	C,W,T,U
<p>This communication object is enabled when the parameter "Floor heating" of "Mixed Thermostat" is selected as "Enabled" and "Indoor temperature source" is selected as "External sensor". This communication object is used to feed back the actual temperature of floor heating to the bus via a 2-byte message.</p>				
160	Floor heating, Setting temperature	2byte-Input	2 bytes	C,W,T,U
<p>This communication object is enabled when the parameter "Floor heating" of "Mixed Thermostat" is selected as "Enabled" and "Setting temperature" is selected as "Enabled". This communication object is used to feed back the message of the floor heating setting temperature to the bus via 2 bytes.</p>				
161	Floor heating, Setting temperature	2byte-Output	2 bytes	C,W,T,U
<p>This communication object is enabled when the parameter "Floor heating" of "Mixed Thermostat" is selected as "Enabled" and "Setting function switch" is selected as "Enabled". This communication object is used to send the status of the floor heating setting temperature through 2 bytes.</p>				
162	Floor heating, Function switch	On/Off-Input	1 bit	C,W,T,U

This communication object is enabled when the parameter "Floor heating" of "Mixed Thermostat" is selected as "Enabled" and "Setting function switch" is selected as "Enabled". This communication object is used to feed back the floor heating on/off message to the bus via 1 bit.

163	Floor heating, Function switch	On/Off-Output	1 bit	C,R,T
-----	--------------------------------	---------------	-------	-------

This communication object is enabled when the parameter "Floor heating" of "Mixed Thermostat" is selected as "Enabled" and "Setting function switch" is selected as "Enabled". This communication object is used to send the on/off status of floor heating through 1 bit.

#### 7.2.4 "Ventilation system" Mode

Number *	Name	Object Function	Description	Group Address	Length	C	R	W	T	U	Data Type	Priority
164	Ventilation system, Fan speed low	On / Off			1 bit	C	R	-	T	-	switch	Low
165	Ventilation system, Fan speed medium	On / Off			1 bit	C	R	-	T	-	switch	Low
166	Ventilation system, Fan speed high	On / Off			1 bit	C	R	-	T	-	switch	Low
167	Ventilation system, Actual temperature	2byte			2 bytes	C	R	W	-	U	temperature (°C)	Low
168	Ventilation system, Setting fan speed	1byte-Input			1 byte	C	R	W	-	U	percentage (0..100%)	Low
169	Ventilation system, Setting fan speed	1byte-Output			1 byte	C	R	-	T	-	percentage (0..100%)	Low
170	Ventilation system, Function switch	On/Off-Input			1 bit	C	R	W	-	U	switch	Low
171	Ventilation system, Function switch	On/Off-Output			1 bit	C	R	-	T	-	switch	Low

Figure 7.2.4

No.	Name	Function	Data length	Attribute
164	Ventilation system, Fan speed low	On/Off	1 bit	C,R,T

This communication object is enabled when the parameter "Ventilation system" of "Mixed Thermostat" is selected as "Enabled", "Fan speed control" is selected as "Enabled" and "Datatype for fan speed control" is selected as "1 bit". This communication object is used to send the low wind speed status of the ventilation system through 1 bit.

164	Ventilation system, Fan speed	1 byte	1 byte	C,R,T
-----	-------------------------------	--------	--------	-------

This communication object is enabled when the parameter "Ventilation system" of "Mixed Thermostat" is selected as "Enabled", "Fan speed control" is selected as "Enabled" and "Datatype for fan speed control" is selected as "1 byte". This communication object is used to send the fan speed status of the ventilation system through 1 byte.

165	Ventilation system, Fan speed medium	On/Off	1 bit	C,R,T
-----	--------------------------------------	--------	-------	-------

This communication object is enabled when the parameter "Ventilation system" of "Mixed Thermostat" is selected as

<p>"Enabled", "Fan speed control" is selected as "Enabled" and "Datatype for fan speed control" is selected as "1 bit". This communication object is used to send the wind speed status of the ventilation system through 1 bit.</p>				
166	Ventilation system, Fan speed high	On/Off	1 bit	C,R,T
<p>This communication object is enabled when the parameter "Ventilation system" of the "Mixed Thermostat" is selected as "Enabled", "Fan speed control" is selected as "Enabled" and "Datatype for fan speed control" is selected as "1 bit". This communication object is used to send the high wind speed status of the ventilation system through 1 bit.</p>				
167	Ventilation system, Actual temperature	2 byte	2 bytes	C,W,T,U
<p>This communication object is enabled when the parameter "Ventilation system" of "Mixed Thermostat" is selected as "Enabled" and "Indoor temperature source" is selected as "Enabled". This communication object is used to feed back the actual temperature message of the ventilation system to the bus via 2 bytes.</p>				
168	Ventilation system, Setting fan speed	1byte-Input	1 byte	C,W,T,U
<p>This communication object is enabled when the parameter "Ventilation system" of the "Mixed Thermostat" is selected as "Enabled" and the parameter "Setting fan speed" is selected as "Enabled". This communication object is used to feed back the fan speed setting message of the ventilation system to the bus via 1 byte.</p>				
169	Ventilation system, Setting fan speed	1byte-Output	1 byte	C,R,T
<p>This communication object is enabled when the parameter "Ventilation system" of "Mixed Thermostat" is selected as "Enabled" and "Setting fan speed" is selected as "Enabled". This communication object is used to send the fan speed setting status of the ventilation system through 1 byte.</p>				
170	Ventilation system, Function switch	On/Off-Input	1 bit	C,W,T,U
<p>This communication object is enabled when the parameter "Ventilation system" of the "Mixed Thermostat" is selected as "Enabled" and the "Setting function switch" is selected as "Enabled". This communication object is used to feed back the ventilation system on/off message to the bus via 1 bit.</p>				

171	Ventilation system, Function switch	On/Off-Output	1 bit	C,R,T
<p>This communication object is enabled when the parameter "Ventilation system" of the "Mixed Thermostat" is selected as "Enabled" and the "Setting function switch" is selected as "Enabled". This communication object is used to send the on/off status of the ventilation system through 1 bit.</p>				

### 7.2.5 "Actual temperature" function

Number *	Name	Object Function	Description	Group Address	Length	C	R	W	T	U	Data Type	Priority
121	Thermostat, Recv actual temperature	2 byte			2 bytes	C	-	W	T	U	temperature (°C)	Low

Figure 7.2.5

No.	Name	Function	Data length	Attribute
121	Thermostat, Recv actual temperature	2 byte	2 bytes	C,W,T,U
<p>This communication object is enabled when the parameter "Actual temperature" of "Mixed Thermostat" is selected as "Enabled" and "Source for actual temperature" is selected as "external knx bus". This communication object is used to receive the temperature value of the external sensor and feedback the actual temperature message to the bus.</p>				

### 7.2.6 "Actual humidity" function

Number *	Name	Object Function	Description	Group Address	Length	C	R	W	T	U	Data Type	Priority
122	Thermostat, Recv actual humidity	2 byte			2 bytes	C	-	W	T	U	humidity (%)	Low

Figure 7.2.6

No.	Name	Function	Data length	Attribute
122	Thermostat, Recv actual humidity	2 byte	2 bytes	C,W,T,U
<p>This communication object is enabled when the parameter "Actual humidity" of "Mixed Thermostat" is selected as "Enabled" and "Source for actual humidity" is selected as "external knx bus". This communication object is used to receive the humidity value of the external sensor and feedback the actual humidity message to the bus.</p>				

## 7.2.7 "Air quality" function

Number *	Name	Object Function	Description	Group Address	Length	C	R	W	T	U	Data Type	Priority
123	Thermostat, Recv actual PM2.5	2 byte			2 bytes	C	-	W	T	U	concentration (µg/m <sup>3</sup> )	Low
124	Thermostat, Recv actual PM10	2 byte			2 bytes	C	-	W	T	U	concentration (µg/m <sup>3</sup> )	Low
125	Thermostat, Recv actual HCHO	2 byte			2 bytes	C	-	W	T	U	concentration (µg/m <sup>3</sup> )	Low
126	Thermostat, Recv actual TVOC	2 byte			2 bytes	C	-	W	T	U	concentration (µg/m <sup>3</sup> )	Low
127	Thermostat, Recv actual CO2	2 byte			2 bytes	C	-	W	T	U	parts/million (ppm)	Low
128	Thermostat, Recv actual AQI	2 byte			2 bytes	C	-	W	T	U	pulses	Low

Figure 7.2.7

No.	Name	Function	Data length	Attribute
123	Thermostat, Recv actual PM2.5	2 byte	2 bytes	C,W,T,U
<p>This communication object is enabled when the parameter "Air Quality page" of "Mixed Thermostat" is set to "Enabled" and "Display actual PM2.5" is set to "external knx bus". This communication object is used to feed back the PM2.5 message in the air quality to the bus.</p>				
124	Thermostat, Recv actual PM10	2 byte	2 bytes	C,W,T,U
<p>This communication object is enabled when the parameter "Air Quality page" of "Mixed Thermostat" is set to "Enabled" and "Display actual PM2.5" is set to "external knx bus". This communication object is used to feed back the PM10 message in the air quality to the bus.</p>				
125	Thermostat, Recv actual HCHO	2 byte	2 bytes	C,W,T,U
<p>This communication object is enabled when the parameter "Air Quality page" of "Mixed Thermostat" is set to "Enabled" and "Display actual PM2.5" is set to "external knx bus". This communication object is used to feed back the HCHO message in the air quality to the bus.</p>				
126	Thermostat, Recv actual TVOC	2 byte	2 bytes	C,W,T,U
<p>This communication object is enabled when the parameter "Air Quality page" of "Mixed Thermostat" is set to "Enabled" and "Display actual PM2.5" is set to "external knx bus". This communication object is used to feed back the TVOC message in the air quality to the bus.</p>				
127	Thermostat, Recv actual CO2	2 byte	2 bytes	C,W,T,U
<p>This communication object is enabled when the parameter "Air Quality page" of "Mixed Thermostat" is set to "Enabled"</p>				

and "Display actual PM2.5" is set to "external knx bus". This communication object is used to feed back the message of CO2 in the air quality to the bus.

128	Thermostat, Recv actual AQI	2 byte	2 bytes	C,W,T,U
-----	-----------------------------	--------	---------	---------

This communication object is enabled when the parameter "Air Quality page" of "Mixed Thermostat" is set to "Enabled" and "Display actual PM2.5" is set to "external knx bus". This communication object is used to feed back the AQI message in the air quality to the bus.

### 7.2.8 "Thermostat backlight" mode

Number *	Name	Object Function	Description	Group Address	Length	C	R	W	T	U	Data Type	Priority
172	Thermostat backlight, Day/Night mode, Change over	Day/Night			1 bit	C	-	W	T	U	day/night	Low
173	Overwrite brightness, Waking thermostat backlight in the day	0%..100%			1 byte	C	-	W	T	U	percentage (0..100%)	Low
174	Overwrite brightness, Waking thermostat backlight at night	0%..100%			1 byte	C	-	W	T	U	percentage (0..100%)	Low
175	Overwrite brightness, Sleeping thermostat backlight in the day	0%..100%			1 byte	C	-	W	T	U	percentage (0..100%)	Low
176	Overwrite brightness, Sleeping thermostat backlight at night	0%..100%			1 byte	C	-	W	T	U	percentage (0..100%)	Low
177	Thermostat backlight, Input from master, Control own backlight	On / Off			1 bit	C	R	W	T	-	switch	Low
178	Thermostat backlight, Master output, Control other's backlight	On / Off			1 bit	C	R	-	T	-	switch	Low
179	Thermostat backlight, Input-triggering, Waking backlight	On / Off			1 bit	C	R	W	T	-	switch	Low
180	Thermostat backlight, Triggering output, Waking backlight	On / Off			1 bit	C	R	W	T	-	switch	Low

Figure 7.2.8

No.	Name	Function	Data length	Attribute
172	Thermostat backlight, Day/Night mode,  Change over	Day/Night	1 bit	C,W,T,U

This communication object is enabled when the parameter "Thermostat backlight" of "Mixed Thermostat" is selected as "Enabled", "Thermostat backlight mode" is selected as "Always" and "Configuration" is selected as "Day / Night mode". This communication object is used to feed back the day / night mode message of the temperature control panel backlight to the bus.

173	Overwrite brightness, thermostat backlight	0%...100%	1 byte	C,W,T,U
-----	--	-----------	--------	---------

This communication object is enabled when "Overwrite brightness of thermostat backlight via object" is selected "Yes" under the premise that "Enabled" is selected for "Thermostat backlight mode" of "Mixed Thermostat", "Always" is selected for

<p>"Thermostat backlight mode" and "Normal mode" is selected for "Configuration". This communication object is used to feed back the message of the overwritten backlight brightness of the thermostat to the bus.</p>				
173	<p>Overwrite brightness, thermostat backlight in the day</p>	0%...100%	1 byte	C,W,T,U
<p>This communication object is enabled when "Yes" is selected for "Overwrite brightness of thermostat backlight via object" in "In the day" under the premise that "Enabled" is selected for "Thermostat backlight mode" of "Mixed Thermostat", "Always" is selected for "Thermostat backlight mode" and "Day / Night mode" is selected for "Configuration". This communication object is used to feed back the message that the backlight brightness of the thermostat is overwritten during the day to the bus.</p>				
173	<p>Overwrite brightness, Waking thermostat at backlight</p>	0%...100%	1 byte	C,W,T,U
<p>This communication object is enabled when "Overwrite brightness of thermostat backlight via object" is selected "Yes" under the premise that "Enabled" is selected for "Thermostat backlight mode" and "Delay mode" is selected for "Thermostat backlight mode" and "Normal mode" is selected for "Configuration". This communication object is used to feed back the message that the thermostat backlight is awakened and the brightness is rewritten to the bus.</p>				
174	<p>Overwrite brightness, thermostat backlight at night</p>	0%...100%	1 byte	C,W,T,U
<p>This communication object is enabled when "Yes" is selected for "Overwrite brightness of thermostat backlight via object" in "At night" under the premise that "Enabled" is selected for "Thermostat backlight mode", "Always" is selected for "Thermostat backlight mode" and "Day / Night mode" is selected for "Configuration". This communication object is used to feed back the message of overwritten backlight brightness of thermostat at night to the bus.</p>				
175	<p>Overwrite brightness, Sleeping</p>	0%...100%	1 byte	C,W,T,U

	thermostat backlight			
<p>This communication object is enabled when "Overwrite brightness of thermostat backlight via object" is selected "Yes" under the premise that "Enabled" is selected for "Thermostat backlight mode" and "Delay mode" is selected for "Thermostat backlight mode" and "Normal mode" is selected for "Configuration". This communication object is used to feed back the message of the overwritten backlight brightness of the thermostat to the bus.</p>				
175	Overwrite brightness, Sleeping thermostat  backlight in the day	0%...100%	1 byte	C,W,T,U
<p>This communication object is enabled when "Yes" is selected for "Overwrite brightness of thermostat backlight via object" in "In the day" under the premise that "Enabled" is selected for "Thermostat backlight mode" and "Delay mode" is selected for "Thermostat backlight mode" and "Day / Night mode" is selected for "Configuration". This communication object is used to feed back the message of the overwritten backlight brightness of the thermostat during the day to the bus.</p>				
176	Overwrite brightness, Sleeping thermostat  backlight at night	0%...100%	1 byte	C,W,T,U
<p>This communication object is enabled when "Yes" is selected for "Overwrite brightness of thermostat backlight via object" in "At night" under the premise that "Enabled" is selected for "Thermostat backlight mode", "Delay mode" is selected for "Thermostat backlight mode" and "Day / Night mode" is selected for "Configuration". This communication object is used to feed back the message of the overwritten backlight brightness of the thermostat at night to the bus.</p>				
177	Thermostat backlight, Input from master,  Control own backlight	On/Off	1 bit	C,R,W,T
<p>This communication object is enabled when "Enabled" is selected for "Thermostat backlight" in the "Mixed Thermostat" parameter, "Delay mode" is selected for "Thermostat backlight mode", "Normal mode" is selected for "Configuration" or "Day / Night mode" is selected for "Configuration", and "delay according to master device" is selected for "Delay time after waking</p>				

backlight". This communication object is used to feedback the thermostat as a slave, and the backlight of the slave is delayed to turn off according to the switch signal sent by the master device.

178	Thermostat backlight, Master output, Control other's backlight	On/Off	1 bit	C,R,T
-----	---	--------	-------	-------

This communication object is enabled when the parameter "Thermostat backlight" of "Mixed Thermostat" is selected as "Enabled", "Thermostat backlight mode" is selected as "Delay mode" and "Master output for controlling other's backlight" is selected as "Yes". This communication object is used for the thermostat to output and control the backlight of other slaves as the master (master-slave function).

179	Thermostat backlight, Input-triggering, Waking backlight	On/Off	1 bit	C,R,W,T
-----	---	--------	-------	---------

This communication object is enabled when the parameter "Thermostat backlight" of "Mixed Thermostat" is selected as "Enabled", "Thermostat backlight mode" is selected as "Delay mode" and "Wake up backlight via object" is selected as "Yes". This communication object is used to wake up the backlight of the thermostat via the object.

180	Thermostat backlight, Triggering output, Waking backlight	On/Off	1 bit	C,R,W,T
-----	--	--------	-------	---------

This communication object is enabled when the parameter "Thermostat backlight" of "Mixed Thermostat" is selected as "Enabled", "Thermostat backlight mode" is selected as "Delay mode" and "Output triggering signal for wakingbacklight" is selected as "Yes". This communication object is used to output a trigger signal when the thermostat backlight is awakened.

### 7.3 Communication object of "Mixed Actuator" — **Not available**

### 7.4 Communication object of "Scene Module"

Number *	Name	Object Function	Description	Group Address	Length	C	R	W	T	U	Data Type	Priority
206	Scene module 1, scene	8 bit value			1 byte	C	R	W	T	-	scene control	Low
207	Scene module 1	Output 1-1 bit			1 bit	C	-	W	T	U	switch	Low
208	Scene module 1	Output 2-1 bit			1 bit	C	-	W	T	U	switch	Low
209	Scene module 1	Output 3-1 bit			1 bit	C	-	W	T	U	switch	Low
210	Scene module 1	Output 4-1 bit			1 bit	C	-	W	T	U	switch	Low
211	Scene module 1	Output 5-1 bit			1 bit	C	-	W	T	U	switch	Low
212	Scene module 1	Output 6-1 bit			1 bit	C	-	W	T	U	switch	Low
213	Scene module 1	Output 7-1 bit			1 bit	C	-	W	T	U	switch	Low
214	Scene module 1	Output 8-1 bit			1 bit	C	-	W	T	U	switch	Low

Figure 7.4.1

No.	Name	Function	Data length	Attribute
206	Scene module 1, scene	8 bit value	1 byte	C,R,W,T
<p>This communication object is enabled when the parameter "Scene module 1" of "Scene module" is selected as "Yes".</p> <p>This communication object calls or stores the scene by sending an 8-bit command. The meaning of the 8-bit command is explained in detail below.</p> <p>Suppose an 8-bit command is (binary code): FXNNNNNN</p> <p>F: "0" calls the scene; "1" stores the scene;</p> <p>X: 0;</p> <p>NNNNNN: scene number (0..63)</p> <p>The parameter setting options are 1~64. In fact, the scene message received by the communication object "Scene handle" corresponds to 0~63. If the parameter is set to scene 1, the communication object "Scene module 1" receives scene 0.</p>				
207	Scene module 1	Output 1-1bit/1 byte	1bit/1 byte	C,W,T,U
<p>This communication object is enabled when the parameter "Scene module 1" of "Scene module" selects "Yes". This communication object controls output 1 to send a 1bit/1 byte command to the outside by calling the scene number.</p>				
208	Scene module 1	Output 2-1bit/1 byte	1bit/1 byte	C,W,T,U
<p>This communication object is enabled when the parameter "Scene module 1" of "Scene module" selects "Yes". This communication object controls output 2 to send a 1bit/1 byte command to the outside by calling the scene number.</p>				

209	Scene module 1	Output 3-1bit/1 byte	1bit/1 byte	C,W,T,U
<p>This communication object is enabled when the parameter "Scene module 1" of "Scene module" selects "Yes". This communication object controls output 3 to send a 1bit/1 byte command to the outside by calling the scene number.</p>				
210	Scene module 1	Output 4-1bit/1 byte	1bit/1 byte	C,W,T,U
<p>This communication object is enabled when the parameter "Scene module 1" of "Scene module" selects "Yes". This communication object controls output 4 to send a 1bit/1 byte command to the outside by calling the scene number.</p>				
211	Scene module 1	Output 5-1bit/1 byte	1bit/1 byte	C,W,T,U
<p>This communication object is enabled when the parameter "Scene module 1" of "Scene module" selects "Yes". This communication object controls output 5 to send a 1bit/1 byte command to the outside by calling the scene number.</p>				
212	Scene module 1	Output 6-1bit/1 byte	1bit/1 byte	C,W,T,U
<p>This communication object is enabled when the parameter "Scene module 1" of "Scene module" selects "Yes". This communication object controls output 6 to send a 1bit/1 byte command to the outside by calling the scene number.</p>				
213	Scene module 1	Output 7-1bit/1 byte	1bit/1 byte	C,W,T,U
<p>This communication object is enabled when the parameter "Scene module 1" of "Scene module" selects "Yes". This communication object controls output 7 to send a 1bit/1 byte command to the outside by calling the scene number.</p>				
214	Scene module 1	Output 8- 1bit/1 byte	1bit/1 byte	C,W,T,U
<p>This communication object is enabled when the parameter "Scene module 1" of "Scene module" selects "Yes". This communication object controls output 8 to send a 1bit/1 byte command to the outside by calling the scene number.</p>				
<p>Scene module X (X=1~8), communication objects are the same as above.</p>				

## 7.5 Communication object of "Logic Function"

### 7.5.1 "OR,AND,XOR,NOR,NAND,XNOR" mode

Number *	Name	Object Function	Description	Group Address	Length	C	R	W	T	U	Data Type	Priority
278	Logic, channel 1, input a of group 1	On / Off			1 bit	C	-	W	T	U	switch	Low
279	Logic, channel 1, input b of group 1	On / Off			1 bit	C	-	W	T	U	switch	Low
280	Logic, channel 1, input c of group 2	On / Off			1 bit	C	-	W	T	U	switch	Low
281	Logic, channel 1, input d of group 2	On / Off			1 bit	C	-	W	T	U	switch	Low
282	Logic, channel 1, input e of group 3	On / Off			1 bit	C	-	W	T	U	switch	Low
283	Logic, channel 1, input f of group 3	On / Off			1 bit	C	-	W	T	U	switch	Low
284	Logic, channel 1, input g of group 4	On / Off			1 bit	C	-	W	T	U	switch	Low
285	Logic, channel 1, input h of group 4	On / Off			1 bit	C	-	W	T	U	switch	Low
286	Logic, channel 1, output of group 1	On / Off			1 bit	C	R	-	T	-	switch	Low
287	Logic, channel 1, output of group 2	On / Off			1 bit	C	R	-	T	-	switch	Low
288	Logic, channel 1, output of group 3	On / Off			1 bit	C	R	-	T	-	switch	Low
289	Logic, channel 1, output of group 4	On / Off			1 bit	C	R	-	T	-	switch	Low

Figure 7.5.1

No.	Name	Function	Data length	Attribute
278	Logic, channel 1, input a of group 1	On /Off	1bit	C,W,T,U
<p>This communication object is enabled when the parameter "Channel 1" of "Logic Function" is selected as "Enabled" and "Function of channel" is selected as "OR, AND, XOR, NOR, NAND, XNOR". This communication object is used to feedback the logic value message of input object a of group 1 on the bus: on ("1")/off ("0").</p>				
279	Logic, channel 1, input b of group 1	On /Off	1bit	C,W,T,U
<p>This communication object is enabled when the parameter "Channel 1" of "Logic Function" is selected as "Enabled" and "Function of channel" is selected as "OR, AND, XOR, NOR, NAND, XNOR". This communication object is used to feedback the logic value message of input object b of group 1 on the bus: on ("1")/off ("0").</p>				
280	Logic, channel 1, input c of group 2	On /Off	1bit	C,W,T,U
<p>This communication object is enabled when the parameter "Channel 1" of "Logic Function" is selected as "Enabled" and "Function of channel" is selected as "OR, AND, XOR, NOR, NAND, XNOR". This communication object is used to feedback the logic value message of the input object c of group 2 on the bus: on ("1")/off ("0").</p>				
281	Logic, channel 1, input d of group 2	On /Off	1bit	C,W,T,U
<p>This communication object is enabled when the parameter "Channel 1" of "Logic Function" is selected as "Enabled" and "Function of channel" is selected as "OR, AND, XOR, NOR, NAND, XNOR". This communication object is used to feedback</p>				

the logic value message of input object d of group 2 on the bus: on ("1")/off ("0").				
282	Logic, channel 1, input e of group 3	On /Off	1bit	C,W,T,U
This communication object is enabled when the parameter "Channel 1" of "Logic Function" is selected as "Enabled" and "Function of channel" is selected as "OR, AND, XOR, NOR, NAND, XNOR". This communication object is used to feedback the logic value message of input object e of group 3 on the bus: on ("1")/off ("0").				
283	Logic, channel 1, input f of group 3	On /Off	1bit	C,W,T,U
This communication object is enabled when the parameter "Channel 1" of "Logic Function" is selected as "Enabled" and "Function of channel" is selected as "OR, AND, XOR, NOR, NAND, XNOR". This communication object is used to feedback the logic value message of the input object f of group 3 on the bus: on ("1")/off ("0").				
284	Logic, channel 1, input g of group 4	On /Off	1bit	C,W,T,U
This communication object is enabled when the parameter "Channel 1" of "Logic Function" is selected as "Enabled" and "Function of channel" is selected as "OR, AND, XOR, NOR, NAND, XNOR". This communication object is used to feedback the logic value message of the input object g of group 4 on the bus: on ("1")/off ("0").				
285	Logic, channel 1, input h of group 4	On /Off	1bit	C,W,T,U
This communication object is enabled when the parameter "Channel 1" of "Logic Function" is selected as "Enabled" and "Function of channel" is selected as "OR, AND, XOR, NOR, NAND, XNOR". This communication object is used to feedback the logic value message of the input object h of group 4 on the bus: on ("1")/off ("0").				
286	Logic, channel 1, output of group 1	On /Off /(1 byte)	1bit/1 byte	C,R,T
This communication object is enabled when the parameter "Channel 1" of "Logic Function" is selected as "Enabled" and "Function of channel" is selected as "OR, AND, XOR, NOR, NAND, XNOR". This communication object is used to send the logic operation result of group 1 and use the result of the logic operation as the switch state output.				
287	Logic, channel 1, output of group 2	On /Off /(1 byte)	1bit/1 byte	C,R,T

This communication object is enabled when the parameter "Channel 1" of "Logic Function" is selected as "Enabled" and "Function of channel" is selected as "OR, AND, XOR, NOR, NAND, XNOR". This communication object is used to send the logic operation result of group 2 and use the result of the logic operation as the switch state output.

288	Logic, channel 1, output of group 3	On /Off /(1 byte)	1bit/1 byte	C,R,T
-----	-------------------------------------	-------------------	-------------	-------

This communication object is enabled when the parameter "Channel 1" of "Logic Function" is selected as "Enabled" and "Function of channel" is selected as "OR, AND, XOR, NOR, NAND, XNOR". This communication object is used to send the logic operation result of group 3 and use the result of the logic operation as the switch state output.

289	Logic, channel 1, output of group 4	On /Off /(1 byte)	1bit/1 byte	C,R,T
-----	-------------------------------------	-------------------	-------------	-------

This communication object is enabled when the parameter "Channel 1" of "Logic Function" is selected as "Enabled" and "Function of channel" is selected as "OR, AND, XOR, NOR, NAND, XNOR". This communication object is used to send the logic operation result of group 4 and use the result of the logic operation as the switch state output.

- ① Channel X (X=1~8), the same as the communication object of channel 1 above.
- ② The above is the communication object with "2 input of 4 group" selected as "Logic combination type", the same as the communication object with parameters such as "3 input of 2 group + 2 input of 1 group", "4 input of 1 group +2 input of 2 group", "4 input of 2 group" selected as "Logic combination type".

### 7.5.2"Threshold comparator"mode

Number *	Name	Object Function	Description	Group Address	Length	C	R	W	T	U	Data Type	Priority
278	Logic, channel 1, threshold value input	2 byte			2 bytes	C	-	W	T	U	pulses	Low
279	Logic, channel 1, output 1 for threshold value	On / Off			1 bit	C	R	-	T	-	switch	Low
280	Logic, channel 1, output 2 for threshold value	On / Off			1 bit	C	R	-	T	-	switch	Low
281	Logic, channel 1, output 3 for threshold value	On / Off			1 bit	C	R	-	T	-	switch	Low
282	Logic, channel 1, output 4 for threshold value	On / Off			1 bit	C	R	-	T	-	switch	Low
283	Logic, channel 1, output 5 for threshold value	On / Off			1 bit	C	R	-	T	-	switch	Low
284	Logic, channel 1, output 6 for threshold value	On / Off			1 bit	C	R	-	T	-	switch	Low

Figure 7.5.2

No.	Name	Function	Data function	Attribute
278	Logic, channel 1, threshold value input	4bit/1byte/2byte	4bit/1byte/2bytes	C,W,T,U

This communication object is enabled when the parameter "Channel 1" of "Logic Function" is selected as "Enabled" and

<p>"Function of channel" is selected as "Threshold comparator". This communication object is used to feed back messages of threshold data type on the bus.</p>				
279	Logic, channel 1, output 1 for threshold value	On /Off	1bit	C,R,T
<p>This communication object is enabled when the parameter "Channel 1" of "Logic Function" is selected as "Enabled" and "Function of channel" is selected as "Threshold comparator". This communication object is used to send the switch state of output 1 when the object value is less than the threshold value.</p>				
280	Logic, channel 1, output 2 for threshold value	On /Off	1bit	C,R,T
<p>This communication object is enabled when the parameter "Channel 1" of "Logic Function" is selected as "Enabled" and "Function of channel" is selected as "Threshold comparator". This communication object is used to send the switch state of output 2 when the object value = threshold value.</p>				
281	Logic, channel 1, output 3 for threshold value	On /Off	1bit	C,R,T
<p>This communication object is enabled when the parameter "Channel 1" of "Logic Function" is selected as "Enabled" and the "Function of channel" is selected as "Threshold comparator". This communication object is used to send the switch state of output 3 when the object value <math>\neq</math> threshold value.</p>				
282	Logic, channel 1, output 4 for threshold value	On /Off	1bit	C,R,T
<p>This communication object is enabled when the parameter "Channel 1" of "Logic Function" is selected as "Enabled" and "Function of channel" is selected as "Threshold comparator". This communication object is used to send the switch state of output 4 when the object value is greater than the threshold value.</p>				
283	Logic, channel 1, output 5 for threshold value	On /Off	1bit	C,R,T
<p>This communication object is enabled when the parameter "Channel 1" of "Logic Function" is selected as "Enabled" and "Function of channel" is selected as "Threshold comparator". This communication object is used to send the switch state of output 5 when the object value is <math>\leq</math> the threshold value.</p>				

284	Logic, channel 1, output 6 for threshold value	On /Off	1bit	C,R,T
<p>This communication object is enabled when the parameter "Channel 1" of "Logic Function" is selected as "Enabled" and "Function of channel" is selected as "Threshold comparator". This communication object is used to send the switch state of output 6 when the object value <math>\geq</math> threshold value.</p>				
<p>Channel X (X=1~8) is the same as the communication object of channel 1 above.</p>				

### 7.5.3 "Data converters" mode

1 ) When the parameter Format convert type is 2x1Bit --> 1x2Bit

Number *	Name	Object Function	Description	Group Address	Length	C	R	W	T	U	Data Type	Priority
278	Logic, channel 1, input 1bit	bit0			1 bit	C	-	W	T	U	switch	Low
279	Logic, channel 1, input 1bit	bit1			1 bit	C	-	W	T	U	switch	Low
280	Logic, channel 1, output	2bit			2 bit	C	R	-	T	-	switch control	Low

Figure 7.5.3.1

No.	Name	Function	Data length	Attribute
278	Logic, channel 1, input 1bit	Bit 0	1bit	C,W,T,U
279	Logic, channel 1, input 1bit	Bit 1	1bit	C,W,T,U
<p>This communication object is enabled when "Enabled" is selected for "Channel 1" of the "Logic Function" parameter, "Data converters" is selected for "Function of channel", "Direct converters" is selected for "Data Convert mode", and "2x1Bit --&gt; 1x2Bit" is selected for "Format convert type". This communication object is used to feed back the message of the Nth (N=1~2) 1-bit input object on the bus.</p>				
280	Logic, channel 1, output	2 bit	2 bit	C,R,T
<p>This communication object is enabled when "Enabled" is selected for "Channel 1" of the "Logic Function" parameter, "Data converters" is selected for "Fuction of channel", "Direct converters" is selected for "Data Convert mode", and "2x1Bit --&gt; 1x2Bit" is selected for "Format convert type". This communication object triggers the data conversion function through two</p>				

1-bit character-sized input objects and sends a 2-bit character-sized output state.

Channel X (X=1~8) is the same as the communication object of channel 1 above.

2 ) When the parameter Format convert type is 8x1Bit --> 1x1Byte

Number ^	Name	Object Function	Description	Group Address	Length	C	R	W	T	U	Data Type
278	Logic, channel 1, input 1bit	bit0			1 bit	C	-	W	T	U	switch
279	Logic, channel 1, input 1bit	bit1			1 bit	C	-	W	T	U	switch
280	Logic, channel 1, input 1bit	bit2			1 bit	C	-	W	T	U	switch
281	Logic, channel 1, input 1bit	bit3			1 bit	C	-	W	T	U	switch
282	Logic, channel 1, input 1bit	bit4			1 bit	C	-	W	T	U	switch
283	Logic, channel 1, input 1bit	bit5			1 bit	C	-	W	T	U	switch
284	Logic, channel 1, input 1bit	bit6			1 bit	C	-	W	T	U	switch
285	Logic, channel 1, input 1bit	bit7			1 bit	C	-	W	T	U	switch
286	Logic, channel 1, ouput	1byte			1 byte	C	R	-	T	-	percentage (0..100%)

Figure 7.5.3.2

No.	Name	Function	Data length	Attribute
278	Logic, channel 1, input 1bit	Bit 0	1bit	C,W,T,U
279	Logic, channel 1, input 1bit	Bit 1	1bit	C,W,T,U
280	Logic, channel 1, input 1bit	Bit 2	1bit	C,W,T,U
281	Logic, channel 1, input 1bit	Bit 3	1bit	C,W,T,U
282	Logic, channel 1, input 1bit	Bit 4	1bit	C,W,T,U
283	Logic, channel 1, input 1bit	Bit 5	1bit	C,W,T,U
284	Logic, channel 1, input 1bit	Bit 6	1bit	C,W,T,U
285	Logic, channel 1, input 1bit	Bit 7	1bit	C,W,T,U

This communication object is enabled when "Enabled" is selected for "Channel 1" of the "Logic Function" parameter, "Data converters" is selected for "Function of channel", "Direct converters" is selected for "Data Convert mode", and "8x1Bit --> 1x1Byte" is selected for "Format convert type". This communication object is used to feed back the message of the Nth (N=1~8) 1-bit input object on the bus.

286	Logic, channel 1, output	1byte	1byte	C,R,T
<p>This communication object is enabled when "Enabled" is selected for "Channel 1" of the "Logic Function" parameter, "Data converters" is selected for "Function of channel", "Direct converters" is selected for "Data Convert mode", and "8x1Bit --&gt; 1x1Byte" is selected for "Format convert type". This communication object triggers the data conversion function through N 1-bit character-sized input objects and sends a 1-byte character-sized output state.</p>				
<p>Channel X (X=1~8), the same as the communication object of channel 1 above</p>				

3 ) When the parameter Format convert type is 1x1Byte --> 1x2Byte

Number ^	Name	Object Function	Description	Group Address	Length	C	R	W	T	U	Data Type
278	Logic, channel 1, input 1byte	byte0			1 byte	C	-	W	T	U	percentage (0..100%)
279	Logic, channel 1, input 1byte	byte1			1 byte	C	-	W	T	U	percentage (0..100%)
280	Logic, channel 1, ouput	2byte			2 bytes	C	R	-	T	-	pulses

Figure7.5.3.3

No.	Name	Function	Data length	Attribute
278	Logic, channel 1, input 1byte	Byte 0	1byte	C,W,T,U
279	Logic, channel 1, input 1byte	Byte 1	1byte	C,W,T,U
<p>This communication object is enabled when "Enabled" is selected for "Channel 1" of the "Logic Function" parameter, "Data converters" is selected for "Function of channel", "Direct converters" is selected for "Data Convert mode" and "1x1Byte --&gt; 1x2Byte" is selected for "Format convert type". This communication object is used to feed back the message of the Nth (N=1~2) 1-byte input object on the bus.</p>				
280	Logic, channel 1, output	2byte	2bytes	C,R,T
<p>This communication object is enabled when "Enabled" is selected for "Channel 1" of the "Logic Function" parameter, "Data converters" is selected for "Function of channel", "Direct converters" is selected for "Data Convert mode", and "1x1Byte --&gt; 1x2Byte" is selected for "Format convert type". This communication object triggers the data conversion function through</p>				

two 1-byte character-sized input objects and sends a 2-byte character-sized output state.

Channel X (X=1~8), the same as the communication object of channel 1 above

4) When the parameter Format convert type is 2x2Byte --> 1x4Byte

Number ^	Name	Object Function	Description	Group Address	Length	C	R	W	T	U	Data Type
278	Logic, channel 1, input 2byte	low			2 bytes	C	-	W	T	U	pulses
279	Logic, channel 1, input 2byte	high			2 bytes	C	-	W	T	U	pulses
280	Logic, channel 1, ouput	4byte			4 bytes	C	R	-	T	-	counter pulses (unsig...

Figure 7.5.3.4

No.	Name	Function	Data length	Attribute
278	Logic, channel 1, input 2byte	low	2bytes	C,W,T,U
<p>This communication object is enabled when "Enabled" is selected for "Channel 1" of the "Logic Function" parameter, "Data converters" is selected for "Function of channel", "Direct converters" is selected for "Data Convert mode" and "2x2Byte --&gt; 1x4Byte" is selected for "Format convert type". This communication object is used to feed back the "low" message of the first 2-bytes input object on the bus.</p>				
279	Logic, channel 1, input 2byte	high	2bytes	C,W,T,U
<p>This communication object is enabled when "Enabled" is selected for "Channel 1" of the "Logic Function" parameter, "Data converters" is selected for "Function of channel", "Direct converters" is selected for "Data Convert mode" and "2x2Byte --&gt; 1x4Byte" is selected for "Format convert type". This communication object is used to feed back the "high" message of the first 2-bytes input object on the bus.</p>				
280	Logic, channel 1, output	4bytes	4bytes	C,R,T
<p>This communication object is enabled when "Enabled" is selected for "Channel 1" of the "Logic Function" parameter, "Data converters" is selected for "Function of channel", "Direct converters" is selected for "Data Convert mode", and "2x2Byte --&gt; 1x4Byte" is selected for "Format convert type". This communication object triggers the data conversion function through</p>				

two 2-Bytes character-sized input objects and sends one 4-byte character-sized output state.

Channel X (X=1~8), the same as the communication object of channel 1 above

5 ) When the parameter Format convert type is 1x1Byte --> 1x8Bit

Number ^	Name	Object Function	Description	Group Address	Length	C	R	W	T	U	Data Type
278	Logic, channel 1, input	1byte			1 byte	C	-	W	T	U	percentage (0..100%)
279	Logic, channel 1, output 1bit	bit0			1 bit	C	R	-	T	-	switch
280	Logic, channel 1, output 1bit	bit1			1 bit	C	R	-	T	-	switch
281	Logic, channel 1, output 1bit	bit2			1 bit	C	R	-	T	-	switch
282	Logic, channel 1, output 1bit	bit3			1 bit	C	R	-	T	-	switch
283	Logic, channel 1, output 1bit	bit4			1 bit	C	R	-	T	-	switch
284	Logic, channel 1, output 1bit	bit5			1 bit	C	R	-	T	-	switch
285	Logic, channel 1, output 1bit	bit6			1 bit	C	R	-	T	-	switch
286	Logic, channel 1, output 1bit	bit7			1 bit	C	R	-	T	-	switch

Figure 7.5.3.5

No.	Name	Function	Data length	Attribute
278	Logic, channel 1, input	1byte	1byte	C,W,T,U
<p>This communication object is enabled when the parameter "Channel 1" of "Logic Function" is selected as "Enabled" and "Function of channel" is selected as "Data converters", "Data Convert mode" is selected as "Direct converters" and "Format convert type" is selected as "1x1Byte --&gt; 1x8Bit". This communication object is used to feedback 1byte</p>				
279	Logic, channel 1, output 1bit	Bit 0	1bit	C,R,T
280	Logic, channel 1, output 1bit	Bit 1	1bit	C,R,T
281	Logic, channel 1, output 1bit	Bit 2	1bit	C,R,T
282	Logic, channel 1, output 1bit	Bit 3	1bit	C,R,T
283	Logic, channel 1, output 1bit	Bit 4	1bit	C,R,T
284	Logic, channel 1, output 1bit	Bit 5	1bit	C,R,T
285	Logic, channel 1, output 1bit	Bit 6	1bit	C,R,T
286	Logic, channel 1, output 1bit	Bit 7	1bit	C,R,T
<p>This communication object is enabled when "Enabled" is selected for "Channel 1" of the "Logic Function" parameter,</p>				

"Data converters" is selected for "Function of channel", "Direct converters" is selected for "Data Convert mode", and "1x1Byte --> 1x8Bit" is selected for "Format convert type". This communication object triggers the data conversion function through a 1-byte character input object and sends 8 1-bit character output states.

Channel X (X=1~8), the same as the communication object of channel 1 above

6 ) When the parameter Format convert type is 1x2Byte --> 2x1Bytet

Number *	Name	Object Function	Description	Group Address	Length	C	R	W	T	U	Data Type
278	Logic, channel 1, input	2byte			2 bytes	C	-	W	T	U	pulses
279	Logic, channel 1, output 1byte	low			1 byte	C	R	-	T	-	percentage (0..100%)
281	Logic, channel 1, output 1byte	high			1 byte	C	R	-	T	-	percentage (0..100%)

Figure 7.5.3.6

No.	Name	Function	Data length	Attribute
278	Logic, channel 1, input	2byte	2bytes	C,W,T,U
<p>This communication object is enabled when "Enabled" is selected for "Channel 1" of the "Logic Function" parameter, "Data converters" is selected for "Function of channel", "Direct converters" is selected for "Data Convert mode" and "1x2Byte --&gt; 2x1Byte" is selected for "Format convert type". This communication object is used to feed back the message of a 2-byte input object on the bus.</p>				
279	Logic, channel 1, output 1byte	low	1byte	C,R,T
<p>This communication object is enabled when "Enabled" is selected for "Channel 1" of the "Logic Function" parameter, "Data converters" is selected for "Function of channel", "Direct converters" is selected for "Data Convert mode", and "1x2Byte --&gt; 2x1Byte" is selected for "Format convert type". This communication object triggers the data conversion function through a 2-byte character input object and sends the first 1-byte character size "low" output state.</p>				
281	Logic, channel 1, output 1byte	high	1byte	C,R,T
<p>This communication object is enabled when "Enabled" is selected for "Channel 1" of the "Logic Function" parameter, "Data converters" is selected for "Function of channel", "Direct converters" is selected for "Data Convert mode" and "1x2Byte</p>				

--> 2x1Byte" is selected for "Format convert type". This communication object triggers the data conversion function through a 2-byte character size input object and sends the second 1-byte character size "high" output state.

Channel X (X=1~8), the same as the communication object of channel 1 above

7 ) When the parameter Format convert type is 1x4Byte --> 2x2Byte

Number *	Name	Object Function	Description	Group Address	Length	C	R	W	T	U	Data Type
278	Logic, channel 1, input	4byte			4 bytes	C	-	W	T	U	counter pulses (unsig...
279	Logic, channel 1, output 2byte	low			2 bytes	C	R	-	T	-	pulses
280	Logic, channel 1, output 2byte	high			2 bytes	C	R	-	T	-	pulses

Figure 7.5.3.7

No.	Name	Function	Data length	Attribute
278	Logic, channel 1, input	4byte	4bytes	C,W,T,U
<p>This communication object is enabled when "Enabled" is selected for "Channel 1" of the "Logic Function" parameter, "Data converters" is selected for "Function of channel", "Direct converters" is selected for "Data Convert mode" and "1x4Byte --&gt; 2x2Byte" is selected for "Format convert type". This communication object is used to feed back a message of a 4-byte input object on the bus.</p>				
279	Logic, channel 1, output 2byte	low	2byte	C,R,T
<p>This communication object is enabled when "Enabled" is selected for "Channel 1" of the "Logic Function" parameter, "Data converters" is selected for "Function of channel", "Direct converters" is selected for "Data Convert mode", and "1x4Byte --&gt; 2x2Byte" is selected for "Format convert type". This communication object triggers the data conversion function through a 4-byte character input object and sends the first 2-byte character size "low" output state.</p>				
281	Logic, channel 1, output 2byte	high	2byte	C,R,T
<p>This communication object is enabled when "Enabled" is selected for "Channel 1" of the "Logic Function" parameter, "Data converters" is selected for "Function of channel", "Direct converters" is selected for "Data Convert mode" and "1x4Byte</p>				

--> 2x2Byte" is selected for "Format convert type". This communication object triggers the data conversion function through a 4-byte character input object and sends the second 2-byte character size "high" output state.

Channel X (X=1~8), the same as the communication object of channel 1 above

8 ) When the parameter Format convert type is 1x3Byte --> 3x1Byte

Number ^	Name	Object Function	Description	Group Address	Length	C	R	W	T	U	Data Type
278	Logic, channel 1, input	3byte			3 bytes	C	-	W	T	U	RGB value 3x(0..255)
279	Logic, channel 1, output 1byte	low			1 byte	C	R	-	T	-	percentage (0..100%)
280	Logic, channel 1, output 1byte	middle			1 byte	C	R	-	T	-	percentage (0..100%)
281	Logic, channel 1, output 1byte	high			1 byte	C	R	-	T	-	percentage (0..100%)

Figure 7.5.3.8

No.	Name	Function	Data length	Attribute
278	Logic, channel 1, input	3byte	3bytes	C,W,T,U
<p>This communication object is enabled when "Enabled" is selected for "Channel 1" of the "Logic Function" parameter, "Data converters" is selected for "Function of channel", "Direct converters" is selected for "Data Convert mode" and "1x3Byte --&gt; 3x1Byte" is selected for "Format convert type". This communication object is used to feed back a message of a 4-byte input object on the bus.</p>				
279	Logic, channel 1, output 1byte	low	1byte	C,R,T
<p>This communication object is enabled when "Enabled" is selected for "Channel 1" of the "Logic Function" parameter, "Data converters" is selected for "Function of channel", "Direct converters" is selected for "Data Convert mode", and "1x3Byte --&gt; 3x1Byte" is selected for "Format convert type". This communication object triggers the data conversion function through a 3-byte character size input object and sends the first 1-byte character size "low" output state.</p>				
280	Logic, channel 1, output 1byte	middle	1byte	C,R,T
<p>This communication object is enabled when "Enabled" is selected for "Channel 1" of the "Logic Function" parameter, "Data converters" is selected for "Function of channel", "Direct converters" is selected for "Data Convert mode", and "1x3Byte --&gt; 3x1Byte" is selected for "Format convert type". This communication object triggers the data conversion function through a</p>				

3-byte character-sized input object and sends the second 1-byte character-sized "medium" output state.

281	Logic, channel 1, output 1byte	high	1byte	C,R,T
-----	--------------------------------	------	-------	-------

This communication object is enabled when "Enabled" is selected for "Channel 1" of the "Logic Function" parameter, "Data converters" is selected for "Function of channel", "Direct converters" is selected for "Data Convert mode" and "1x3Byte --> 3x1Byte" is selected for "Format convert type". This communication object triggers the data conversion function through a 3-byte character size input object and sends the third 1-byte character size "high" output state.

Channel X (X=1~8), the same as the communication object of channel 1 above

9 ) When the parameter Format convert type is 3x1Byte --> 1x3Byte

Number ^	Name	Object Function	Description	Group Address	Length	C	R	W	T	U	Data Type
278	Logic, channel 1, input 1byte	low			1 byte	C	-	W	T	U	percentage (0..100%)
279	Logic, channel 1, input 1byte	middle			1 byte	C	-	W	T	U	percentage (0..100%)
280	Logic, channel 1, input 1byte	high			1 byte	C	-	W	T	U	percentage (0..100%)
281	Logic, channel 1, output	3byte			3 bytes	C	R	-	T	-	RGB value 3x(0..255)

Figure 7.5.3.9

No.	Name	Function	Data length	Attribute
278	Logic, channel 1, input 1byte	low	1byte	C,W,T,U

This communication object is enabled when "Enabled" is selected for "Channel 1" of the "Logic Function" parameter, "Data converters" is selected for "Function of channel", "Direct converters" is selected for "Data Convert mode" and "3x1Byte --> 1x3Byte" is selected for "Format convert type". This communication object is used to feed back the "low" message of the first 1-byte input object on the bus.

279	Logic, channel 1, input 1byte	middle	1byte	C,W,T,U
-----	-------------------------------	--------	-------	---------

This communication object is enabled when "Enabled" is selected for "Channel 1" of the "Logic Function" parameter, "Data converters" is selected for "Function of channel", "Direct converters" is selected for "Data Convert mode" and "3x1Byte --> 1x3Byte" is selected for "Format convert type". This communication object is used to feed back the "medium" message of

the second 1-byte input object on the bus.				
280	Logic, channel 1, input 1byte	high	1byte	C,W,T,U
<p>This communication object is enabled when "Enabled" is selected for "Channel 1" of the "Logic Function" parameter, "Data converters" is selected for "Function of channel", "Direct converters" is selected for "Data Convert mode" and "3x1Byte --&gt; 1x3Byte" is selected for "Format convert type". This communication object is used to feed back the "high" message of the third 1-byte input object on the bus.</p>				
281	Logic, channel 1, output	3byte	3bytes	C,R,T
<p>This communication object is enabled when "Enabled" is selected for "Channel 1" of the "Logic Function" parameter, "Data converters" is selected for "Function of channel", "Direct converters" is selected for "Data Convert mode", and "3x1Byte --&gt; 1x3Byte" is selected for "Format convert type". This communication object triggers the data conversion function through three 1-byte character-sized input objects and sends one 3-byte character-sized output state.</p>				
Channel X (X=1~8), the same as the communication object of channel 1 above				

### 10 ) When the parameter Data Convert mode is Value converters

Number ^	Name	Object Function	Description	Group Address	Length	C	R	W	T	U	Data Type
278	Logic, channel 1, input	1bit			1 bit	C	-	W	T	U	switch
279	Logic, channel 1, output	1bit			1 bit	C	R	-	T	-	switch

Figure 7.5.3.10

No.	Name	Function	Data length	Attribute
278	Logic, channel 1, input	1bit/2bit/1byte/2bytes	1bit/2bit/1byte/2bytes	C,W,T,U
<p>This communication object is enabled when "Enabled" is selected for "Channel 1" of the "Logic Function" parameter, "Data converters" is selected for "Function of channel", and "Value converters" is selected for "Data Convert mode". This communication object is used to feed back the message of the input object on the bus.</p>				
279	Logic, channel 1,output	1bit/2bit/1byte/2bytes	1bit/2bit/1byte/2bytes	C,R,T

This communication object is enabled when "Enabled" is selected for "Channel 1" of the "Logic Function" parameter and "Data converters" is selected for "Function of channel", and "Value converters" is selected for "Data Convert mode". This communication object sends the status of the output object through the data conversion function.

Channel X (X=1~8), the same as the communication object of channel 1 above

## 7.6 Communication object “ Device status”

Number *	Name	Object Function	Description	Group Address	Length	C	R	W	T	U	Data Type	Priority
205	Panel funciton, Device status	On / Off			1 bit	C	R	-	T	-	switch	Low

Figure 7.6.1

No.	Name	Function	Data length	Attribute
205	Panel function, Device status	On/Off	1bit	C,R,T

This communication object is enabled when the parameter "Device status" of "Panel functions" is selected as "Enabled".

This communication object is used to send the device online status.

## 8. Safe use and maintenance

- (1) Read all instructions carefully before use.
- (2) Create a well-ventilated environment.
- (3) During use, pay attention to moisture, shock and dust prevention.
- (4) Do not expose to rain, other liquids or corrosive gases.
- (5) If the machine is exposed to moisture or liquid, dry it in time.
- (6) If the machine fails, please contact professional maintenance personnel or our company.

## **9. Contact**

**Control4u**

Address: Vardinon 3 Floor 7, 708, Petah -Tiqwa , Israel, 4959507